

# Request for Bid Proposal, Contract Documents, and Specifications

**Doctor's Office Lane Sewer Rehabilitation Project  
HCSD Project No. 06-1909**



**Humboldt Community Services District  
Humboldt County, California**

**February 2025**

**Bids due by 5:00 p.m. on March 20, 2025**

**This Page Left Intentionally Blank**

# Request for Bid Proposal, Contract Documents, and Specifications

**Doctor's Office Lane Sewer Rehabilitation Project  
HCSD Project No. 06-1909**



**Humboldt Community Services District Humboldt County, California**

5055 Walnut Drive  
P.O. Box 158  
Cutten, CA 95534  
Tel: 707-443-4558  
Fax: 707-443-0818

**This Page Left Intentionally Blank**

# TABLE OF CONTENTS

	<b>Page</b>
NOTICE TO CONTRACTORS .....	1
ADVERTISEMENT FOR BIDS.....	3
SUBMITTAL INFORMATION .....	5
PROPOSAL REQUIREMENTS AND CONDITIONS.....	7
GENERAL CONDITIONS .....	13
AWARD AND EXECUTION OF CONTRACT .....	21
PROPOSAL TO THE BOARD OF DIRECTORS .....	23
BID SCHEDULE (Attachment B) .....	25
AGREEMENT .....	29
INSURANCE REQUIREMENTS (Attachment C) .....	49
NON-COLLUSION AFFIDAVIT TO BE EXECUTED BY EACH AWARDEE OF A PRINCIPAL CONTRACT .....	53
NOTARY ACKNOWLEDGMENT .....	55
PERFORMANCE BOND–100% .....	57
PAYMENT BOND–100% .....	59
CONTRACTOR’S/SUBCONTRACTOR’S CERTIFICATION CONCERNING STATE LABOR STANDARDS AND PREVAILING WAGES .....	61
TECHNICAL SPECIFICATIONS .....	63
Section 01 22 00 Measurement and Payment .....	65
<b>Appendices</b>	
A. Construction Plan Sheets (Attachment A) .....	75

**This Page Left Intentionally Blank**

# **Contract Documents**

**This Page Left Intentionally Blank**



## NOTICE TO CONTRACTORS

The Humboldt Community Services District (District), will receive sealed proposals sent to 5055 Walnut Drive, Eureka 95503 until **March 20, 2025, at 5:00 p.m.** Proposals will be publicly opened and read in a Zoom meeting to be scheduled **March 21, 2025 at 3:30 p.m.**

Linked here: <https://us02web.zoom.us/j/87199350115?pwd=iHsDYCbqxzfOaOb0okqLRiphIbNKYA.1>  
Meeting ID: 871 9935 0115  
Passcode: 135360

For performing work in accordance with the Plans and Specifications, therefore, as follows:

### **Doctor's Office Lane Sewer Rehabilitation Project**

Bids are required for the entire work as described herein:

The Doctor's Office Lane Sewer Rehabilitation Project consists of replacing +/- 85 feet of existing 6-inch Vitrified Clay Line with 6" PVC and lining +/- 250 feet of the existing 6-inch vitrified clay line with folded PVC liner. Additionally, the contractor will be responsible for excavating and replacing existing vitrified sewer laterals from the mainline to the edge of the public right of way with 4-inch PVC laterals and bringing each property line cleanout to grade to District Standards. The contractor shall camera all new sanitary sewer lines and depth measurements are to be recorded before accepting into service. Finally, the contractor will be responsible for constructing a new manhole and removing and replacing an existing manhole frame per District Standards.

Project shall be completed in a window beginning April 1, 2025 and terminating by October 31, 2025 over 50 consecutive working days or \$1,000 per day liquidated damages shall be assessed to Contractor.

#### **Contractor shall note the following:**

- Insurance and workers compensation is required.
- Humboldt Community Services District holds an Annual Encroachment Permit with Humboldt County that this project can operate under as long as the Contractor honors the requirements listed under the permit listed under the Encroachment Notes on Sheet 1 of the plans.
- Contractor is responsible for generating and submitting a "Maintaining Sewer Service Work Plan" for District review **at minimum 30 days before work begins** that will outline the contractors plan to complete new sewer construction while maintaining sewer service.
- The Contractor shall be responsible for submitting a shoring plan to the District prior to Construction for Approval
- Performance Bond for 100% of the bid amount is required.
- Payment Bond for 100% of the bid amount is required.
- A mandatory pre-bid meeting will be held at **3:30 P.M. February 20, 2025**. The pre-bid meeting will be a web-based Zoom meeting. Prospective prime contractors shall email the District's Assistant Engineer at [engineer@humboldtcsd.org](mailto:engineer@humboldtcsd.org) in order to register for the meeting. The subject line of the email from the prospective contractors shall be: "Doctor's Office Lane Sewer Rehabilitation Pre-Bid

Meeting Request." All prospective prime contractors are required to attend the meeting to be eligible to bid on this project.

Linked Here:

<https://us02web.zoom.us/j/3889636754?pwd=6bl1axn5P8KoX0aRCFRPMXQK1y1CzB.1&omn=81769714303>

Meeting ID: 388 963 6754

Passcode: 202520

- This is a prevailing wage project.
- Contractor may stage equipment at the Humboldt Community Services District Yard throughout the duration of the project. However, the contractor may only access staged equipment and materials **during work hours 8:00 a.m. - 5:00 p.m. Monday through Friday**. The District is not liable for any vandalism, damages, or stolen equipment or materials.

The foregoing description of work and quantities is approximate only, being given as a basis for the comparison of bids, and the District does not, expressly or by implication, agree that the actual amount of work will correspond therewith, but reserves the right to increase or decrease the amount of any class or portion of the work, or to omit portions of the work, as may be deemed necessary or advisable by the District.

Plans, Specifications, and proposal forms to be used for bidding can only be obtained at the District Office, 5055 Walnut Drive Eureka, California 95503; (707) 443-4558.

The minimum wage rate to be paid under this Contract shall be the current prevailing wage in accordance with Section 1770, and following, of the California Labor Code as determined by the Director of California Department of Industrial Relations; and the General Wage Determinations issued under the Davis-Bacon and Related Acts, as follows:

- General Wage Rate Decision
- Index No. 2019-1 and modifications thereto

The Contractor shall pay whichever rate is higher.

The successful bidder shall post a copy of prevailing wage rates at each job site.

Humboldt Community Services District

Terrence Williams  
General Manager

FEB. 4, 2025

Dated

**\*\*END SECTION\*\***

# **ADVERTISEMENT FOR BIDS**

## **HUMBOLDT COMMUNITY SERVICES DISTRICT 5055 Walnut Drive, Eureka, CA 95503**

The specifications for the project are available on the District's website: <https://humboldtcsd.org/public-notices>. Printed packages are available from the Humboldt Community Services District Office by appointment only between the hours of 8:00 a.m. and 4:00 p.m. Monday through Friday. To schedule an appointment, please call (707) 443-4550.

Sealed bids will be received by the Humboldt Community Services District at the District office at 5055 Walnut Drive, Eureka, CA 95503 until **5:00 p.m. Pacific Time, March 20, 2025**. Bids will be opened and read aloud at a public Zoom meeting to be held at **3:30 p.m. Pacific Time on March 21, 2025**. Sealed bid documents must be received in person or by US Mail or another courier. No fax or email bids will be accepted. It is estimated that the lowest responsible, responsive bidder will be provided notice of award as early as **March 26, 2025**. The successful bidder will then have **50 consecutive work days from April 1, 2025 and completed no later than October 31, 2025**, to complete the Doctor's Office Lane Sewer Rehabilitation Project.

The project extents are located within the Public Right of Way, and as such, Humboldt Community Services District holds an Annual Encroachment Permit with Humboldt County that this project can operate under as long as the Contractor honors the requirements listed under the permit listed under the Encroachment Notes on Sheet 1 of the plans.

The contractor will be able to stage equipment and material in the yard of Humboldt Community Services District. However, the contractor will only be able to access staged equipment and materials during work hours 8:00 a.m. - 5:00 p.m. Monday through Friday. The District is not liable for any vandalism, damages, or stolen equipment or materials.

A mandatory pre-bid meeting will be held at **3:30 P.M. February 20, 2025**. The pre-bid meeting will be a web-based Zoom meeting. Please find the instructions for attending in the Notice to Contractors on page 2 of this section. Please email the District's Assistant Engineer at [engineer@humboldtcsd.org](mailto:engineer@humboldtcsd.org) to register for the meeting. The subject line of the email from the prospective contractors shall be: "Doctor's Office Lane Sewer Rehabilitation Pre-Bid Meeting Request." All prospective prime contractors are required to attend the meeting to be eligible to bid on this project.

The Humboldt Community Services District reserves the right to reject any and all bids. The Humboldt Community Services District will not be liable for any cost incurred by the bidder incidental to the preparation, submittal, or evaluation of their bids, or in the negotiation, execution, and delivery of an agreement that may be awarded as a result of this Advertisement for Bids.

Kush Rawal  
Assistant Engineer  
Humboldt Community Services District

**This Page Left Intentionally Blank**

## SUBMITTAL INFORMATION

### Materials To Be Submitted

The following items must be submitted in response to this Bid Solicitation:

1. Completed and signed Bid Sheet
2. Signed acknowledgment of any Amendments issued by District
3. Proposal Guaranty in the amount of 10% of the bid amount
4. CA Department of Industrial Relations Public Works Contractor Registration Number
5. Completed and signed proposal
6. Completed, signed, and notarized Non-Collusion affidavit

### Tentative Schedule

Mandatory Pre-Bid Meeting (Zoom):	<b>3:30 p.m. February 20, 2025</b>
Deadline for Contractor Questions:	<b>5:00 p.m. February 27, 2025</b>
Bid Addendum (Response to Questions) issued:	<b>March 6, 2025</b>
Bids Due:	<b>5:00 p.m. March 20, 2025</b>
Bid Opening (Zoom):	<b>3:30 p.m. March 21, 2025</b>
Estimated Bid Award/Notice to Proceed:	<b>March 26, 2025</b>
Project Completion:	<b>On or before October 31, 2025</b>

### Submittal Information

Sealed Bid documents are to be addressed to:  
Attn:

**Doctor's Office Lane Sewer Rehabilitation Project.  
Project Bid**  
Humboldt Community Services District  
5055 Walnut Drive  
Eureka, CA 95503

Sealed Bid documents must be received in person or by US Mail or another courier. **No fax or email bids will be accepted.**

Bid documents must be received by **5:00 p.m. Pacific Time on March 20, 2025**. Bid documents received late will not be considered.

**Questions shall be emailed to the project engineer listed below. Email subject line shall state project name as it appears on the cover of these bid documents.**

Kush Rawal, Assistant Engineer  
HCSD  
Email: [engineer@humboldtcsd.org](mailto:engineer@humboldtcsd.org)

**\*\* END OF SECTION\*\***

**This Page Left Intentionally Blank**

## **PROPOSAL REQUIREMENTS AND CONDITIONS**

### **1. Proposal Forms**

All proposals shall be made upon the blank form of the bid packet attached to this document. Proposals submitted on forms other than those issued to the bidder will be disregarded. All proposals must be originals and must give the proposed unit prices, both in writing and in figures, and shall be signed in ink by the bidder, with their address, email, phone, and FAX contact information.

Where required on the bid form, bidders must quote on all items, and they are hereby warned that failure to do so may disqualify the bid. When quotations on all items are not required, bidders shall insert the words "No Bid" in the space provided for any item on which no quotation is made. If the proposal is made by an individual, the individual's name and mailing address shall be shown; if made by a firm or partnership, the name and mailing address of each member of the firm or partnership shall be shown; or if made by a corporation, the proposal shall show the name of the State under the laws of which the corporation was chartered, and the name, titles, and business addresses of the President, Secretary, and Treasurer.

Bids shall be delivered to the District, 5055 Walnut Drive, Eureka, California 95503, on or before the day and hour set for the opening of bids in the advertised "Notice to Contractors." The Bids shall be submitted in a sealed envelope and shall bear the title of the work and the name of the bidder. It is the sole responsibility of the bidder to see that their bid is received by the proper time. All bids received after the scheduled closing time for receipt of the bids shall be returned to the bidder unopened.

### **2. Approximate Estimate**

The quantities given in the proposal and Contract forms are approximate only, being given as a basis for any comparison of bids. The District does not, expressly or by implication, agree that the actual amount of work will correspond therewith, but reserves the right to increase or decrease the amount of any class or portion of the work, or to omit portions of the work as may be deemed necessary or expedient by the District.

In addition to the lump sum costs, bidders are required to provide a per unit cost in the event that actual in-field quantities exceed those listed. As such, per unit costs associated with traffic control, pipe installation and removal, earthwork, and paving are listed as additive bid items.

### **3. Examination of Plans, Specifications, Special Provisions, and Site of the Work**

The bidder shall carefully examine the site of the work contemplated, and the proposal, Plans, Specifications, and Contract Forms therefore. The District builds to the 2022 California Plumbing Code and the most current American Water Works Association standards. The HCSD Construction Design and Construction Standards are located under reports on the District website (<https://humboldtcsd.org/all-reports>) linked here ([https://humboldtcsd.org/documents/1830/Des\\_Construc\\_Std\\_1.pdf](https://humboldtcsd.org/documents/1830/Des_Construc_Std_1.pdf)). The project plans and specifications supersede currently published District design and construction standards. It will be assumed that the bidder has investigated and is satisfied as to the conditions to be encountered, regarding character, quality, and quantities of work to be performed, and the materials to be furnished, and as to the requirements of these Specifications, Special Provisions, and Contract. It is mutually

agreed that submission of a proposal shall be considered "prima facie" evidence that the bidder has made such examination.

#### **4. Proposal Guaranty**

All bids for this Project shall be accompanied by one of the following forms of bidder's security in the amount of 10% of the total bid amount:

- A. Cash; or
- B. A cashier's check made payable to the District; or
- C. A certified check made payable to the District; or
- D. A bidder's bond executed by an admitted surety insurer, made payable to the District.

#### **5. Designation of Subcontractors**

All subcontractors doing work in excess of one-half of one percent ( $\frac{1}{2}\%$ ) of the total bid amount shall be designated on page 9 of the bid packet contained within this volume.

#### **6. Payment to Contractor and Completion**

- A. By the tenth (10th) day of each month, Contractor shall submit to the District for review, an Invoice signed by the Contractor covering the Work completed as of the close of the preceding month and accompanied by such supporting documentation as is required by the Contract Documents. If payment is requested on the basis of materials and equipment not incorporated in the Work but delivered and suitably stored at the Site or at another location agreed to in writing, the Invoice shall also be accompanied by a Bill of Sale/Invoice/or other documentation warranting that the District has received the materials and equipment free and clear of all Liens and evidence that the materials and equipment are covered by appropriate property insurance or other arrangements to protect the District's interest therein, all of which must be satisfactory to the District.
- B. The District will either approve and process payment to the Contractor or return the Invoice to the Contractor within 10 days after receipt indicating, in writing, the reasons for nonpayment. In the latter case, Contractor may make the necessary corrections and resubmit the Invoice for payment.
- C. Approved payments will be processed within thirty (30) days of invoice acceptance.
- D. The District shall retain five percent (5%) of each invoiced value as part security for the fulfillment of the contract by the Contractor, and shall, within thirty (30) days of the date which the estimate is received, pay to the Contractor the balance of such estimated value after deducting therefrom all previous payments and sums to be kept or retained under the terms of the contract. All amounts so retained are withheld subject to the provisions of Public Contract Code Section 7107.

Pursuant to Section 20104.50 of the Public Contract Code, should the District fail to make a progress payment within thirty days after receipt of the undisputed and properly submitted pay estimate from the Contractor, the Contractor is entitled to interest from the District at the then-prevailing legal rate.



Pursuant to Public Contractor Code Section 22300, Contractor may substitute securities for any amount withheld as a retention by the District to ensure performance under the Contract. Such securities, if deposited by the Contractor, shall be valued by the District, whose decision on valuation of the securities shall be final. Securities eligible under this provision shall be limited to those listed in Section 16430 of the Government Code, bank or savings and loan certificates of deposit, interest-bearing demand deposit accounts, standby letters of credit or any other security mutually agreed to by the Contractor and the District.

## **7. Rejection of Proposals**

Proposals may be rejected if they show any alterations of form; additions not called for, conditional bids, incomplete bids, erasures, or irregularities of any kind. The District reserves the right to reject any and/or all proposals.

## **8. Withdrawal of Proposals**

Any bid may be withdrawn at any time prior to the hour fixed in the Notice to Contractors for the opening of bids, provided that a request in writing, executed by the bidder or their duly authorized representative, for the withdrawal of such bid, is filed with the District General Manager. The withdrawal of a bid will not prejudice the right of the bidder to file a new bid. Whether or not bids are opened exactly at the time fixed in the advertised Notice to Contractors, a bid will not be received after that time, nor may a bid be withdrawn after the time fixed in such notice.

## **9. Disqualification of Bidders**

No more than one (1) proposal from an individual, firm, partnership, corporation, or combination thereof under the same or different names, will be considered. Reasonable grounds for believing that any bidder is interested in more than one proposal for the work contemplated will cause the rejection of all proposals in which such bidder is interested. If there is reason for believing that collusion exists among the bidders, none of the participants in such collusion will be considered in future proposals. Proposals in which the prices obviously are unbalanced may be rejected.

## **10. Competency of Bidders**

Bidders must be capable of performing the various items of work bid upon. The lowest bidder, if required by the District, shall furnish, prior to the award of the Contract, a satisfactory statement of their financial responsibility.

## **11. Material Guaranty**

Before any contract is awarded, the bidder may be required to furnish a complete statement of the origin, composition, and manufacture of any and all materials to be used in the construction of the work, together with samples, which may be subjected to the tests provided for in these Specifications, to determine their quality and fitness for the work.

## **Addenda**

If any person contemplating submitting a bid for the proposed Contract is in doubt as to the true meaning of any part of the Plans, Specifications, or other proposed Contract Documents, or finds discrepancies in or omissions from the Drawings or Specifications, he/she may submit to the District a written request for an interpretation or correction thereof. The person submitting the request shall deliver said request no later than **5:00 p.m. on February 27, 2025**. Any interpretation or correction of the proposed documents will be made only by Addendum duly issued; and a copy of such Addendum will be mailed or delivered to each person receiving a set of such documents. The District will not be responsible for any other explanations or interpretations of the proposed documents.

**\*\* END OF SECTION\*\***

**LIST OF SUBCONTRACTORS**

**Doctor's Office Lane Sewer Rehabilitation Project**

Each BIDDER shall list below the name and business address of each SUBCONTRACTOR who will perform work or render service under this CONTRACT in or about the construction of the improvements, or a SUBCONTRACTOR, who specially fabricates and installs a portion of the work or improvement according to detailed DRAWINGS contained in the plans, in excess of one-half of one percent of the total amount shown in the Proposal, and shall also list the portion of the work which will be done by such SUBCONTRACTOR.

<b>Work to be Performed</b>	<b>Percentage of Work</b>	<b>Contractors License</b>	<b>DIR #</b>	<b>Subcontractor's Name, Address, and Contact Person</b>
-----	-----	-----	-----	----- ----- -----
-----	-----	-----	-----	----- ----- -----
-----	-----	-----	-----	----- ----- -----
-----	-----	-----	-----	----- ----- -----
-----	-----	-----	-----	----- ----- -----
-----	-----	-----	-----	----- ----- -----

Additional numbered pages may be attached to this page if sufficient space is not provided hereon.

**This Page Left Intentionally Blank**

## GENERAL CONDITIONS

### 1. Laws, Regulations and Permits

The Contractor shall give all notices required by law and comply with all laws, ordinances, rules, and regulations pertaining to the conduct of the work. The Contractor shall be liable for all violations of the law in connection with work furnished by the Contractor. If the Contractor observes that the Drawings or Specifications are at variance with any law or ordinance, rule, or regulation, he/she shall promptly notify District in writing and any necessary changes shall be made by written instruction or change order. If the Contractor performs any work knowing it to be contrary to such laws, ordinances, rules, or regulations and without giving notice to District, the Contractor shall bear all costs arising therefrom. Humboldt Community Services District holds an Annual Encroachment Permit with Humboldt County that this project can operate under as long as the Contractor honors the requirements listed under the permit listed under the Encroachment Notes on Sheet 1 of the plans. The Contractor shall be responsible for implementing Best Management Practices (BMPs) during all phases of construction, to control stormwater runoff, sedimentation, and erosion on the project site. These BMPs shall include, but are not limited to, the following:

- A. **Erosion and Sediment Control:** The Contractor shall install, maintain, and monitor erosion and sediment control measures in accordance with the California Stormwater Quality Association (CASQA) Manual. These measures shall include, but not be limited to:
  - Silt fences, sediment barriers, and hay bales at construction site perimeters.
  - Temporary and permanent erosion control mats or blankets on disturbed slopes.
  - Sediment basins and traps for stormwater runoff retention.
- B. **Drainage Control Systems:** The Contractor shall design and maintain drainage control systems to prevent surface water runoff from eroding the site or surrounding areas. Such systems must be capable of managing stormwater in a manner that prevents downstream water quality degradation and maintains the stability of disturbed areas. This includes:
  - Diversion berms or swales to redirect runoff away from disturbed areas.
  - Proper protection for stormwater inlets to prevent sediment transport.
  - Regular inspection of drainage infrastructure to ensure functionality during rain events.
- C. **Rain Event Monitoring and Response:** The Contractor shall monitor weather conditions and anticipate rain events. In advance of forecasted rainfall, the Contractor shall take necessary steps to protect the site and surrounding areas from runoff and sediment transport. If rain events are imminent, the Contractor shall:
  - Deploy additional temporary sediment controls, such as additional silt fences or straw waddles.
  - Implement measures to stabilize soil and prevent excessive erosion, including the use of hydroseeding, mulching, or other rapid stabilization techniques.
  - Ensure that all BMPs are in place and functioning as intended prior to any rain events.
- D. **Maintenance and Inspection of BMPs:** The Contractor shall maintain all BMPs in good working condition throughout the duration of construction. BMPs shall be inspected at least once every 7 days and within 24 hours after any rain event of 0.5 inches or more. Any damaged or ineffective BMPs shall be immediately repaired or replaced. The Contractor shall maintain a record of these inspections and repairs.

The Contractor's failure to comply with the above BMPs or to maintain an effective system for controlling stormwater runoff may result in penalties, including but not limited to, suspension of work or withholding of payment until corrective actions are completed.

The Contractor shall bear all costs associated with the implementation, monitoring, and maintenance of the BMPs.

## **2. Safety**

In the performance of this Contract the Contractor shall comply with all applicable federal, state, and local statutory and regulatory requirements including, but not limited to California Department of Industrial Relations (Cal-OSHA) regulations; and the U.S. Department of Transportation Omnibus Transportation Employee Testing Act related to their scope of work and operations. In case of conflict in regulations, the most stringent shall apply. The Contractor shall provide all safeguards, safety devices, and protective equipment and take any other needed actions necessary to protect the life and health of employees on the job and the safety of the public and to protect property in connection with the performance of the work covered by the Contract. Safety precautions shall include, but shall not be limited to: adequate life protection and lifesaving equipment; adequate illumination; instructions in accident prevention for all employees, such as, the use of machinery guards, safe walkways, scaffolds, ladders, bridges, gang planks, confined space procedures, trenching and shoring, fall protection, and other safety devices; equipment and wearing apparel as are necessary or lawfully required to prevent accidents, injuries, or illnesses; and adequate facilities for the proper inspection and maintenance of all safety measures.

Contractor must obtain all applicable Division of Occupational Safety and Health (CAL-OSHA) permit(s) and others required by California Labor Code and California Government Code, prior to the initiation of any practices, work, method, operation, or process related to the work covered in the Contract.

It is a condition of this Contract, and shall be made a condition of each subcontract into which the Contractor enters pursuant to this Contract, that the Contractor and any subcontractor shall not permit any employee, in performance of the Contract, to work in surroundings or under conditions that are unsanitary, hazardous, or dangerous to their health or safety, as determined under Cal-OSHA safety and health standards.

The Contractor shall be responsible for the safeguarding of all utilities. At least two working days before beginning work, the Contractor shall call Underground Service Alert (USA) in order to determine the location of sub-structures. The Contractor shall immediately notify District and the utility owner if Contractor disturbs, disconnects, or damages any utility.

In accordance with Section 6705 of the California Labor Code, the Contractor shall submit to District specific plans to show details of provisions for worker protection from caving ground during excavations of trenches of five (5) feet or more in depth. The excavation/trench safety plan shall be submitted to and accepted by District prior to starting excavation. The trench safety plan shall have details showing the design of shoring, bracing, sloping, or other provisions to be made for worker protection from the hazard of caving ground. If such a plan varies from the shoring system standards established by the Construction Safety Orders of the California Department of Industrial Relations (Cal-OSHA), the plan shall be prepared by a California registered civil or structural engineer. As part of the plan, a note shall be included stating that the registered civil or structural engineer certifies that the plan complies with

the Cal-OSHA Construction Safety Orders, or that the registered civil or structural engineer certifies that the plan is not less effective than the shoring, bracing, sloping, or other provisions of the Safety Orders. In no event shall the Contractor use a shoring, sloping, or protective system less effective than that required by said Construction Safety Orders. Submission of this plan in no way relieves the Contractor of the requirement to maintain safety in all areas. If excavations or trench work requiring a Cal-OSHA permit are to be undertaken, the Contractor shall submit their permit with the excavation/trench work safety plan to District before work begins.

### **3. Subletting Or Assigning the Contract**

- A. The Contractor shall perform with Contractor's own organization Contract work amounting to not less than 50 percent of the original total Contract price, except that any items designated by the District as "Specialty Items" may be performed by subcontract and the amount of any such "Specialty Items" so performed may be deducted from the original total Contract price before computing the amount of work required to be performed by the Contractor with their own organization.
  - 1) "Contractor's own organization" shall be construed to include only workers employed and paid directly by the prime Contractor and equipment owned or rented by Contractor, with or without operators.
  - 2) "Specialty Items" shall be construed to be limited to work that requires highly specialized knowledge, craftsmanship, or equipment not ordinarily available in contracting organizations qualified to bid on the Contract as a whole and in general are to be limited to minor components of the overall Contract.
- B. In addition to the 50 percent requirement set forth in paragraph 1 above, the Contractor shall furnish:
  - 1) a competent superintendent or foreman who is employed by Contractor, who has full authority to direct performance of the work in accordance with the Contract requirements, and who is in charge of all construction operations (regardless of who performs the work); and
  - 2) such other of Contractor's own organizational capability and responsibility (supervision, management, and engineering services) as the District contracting officer determines is necessary to ensure the performance of the Contract.
- C. The Contract amount upon which the 50 percent requirement set forth in paragraph 1 is computed includes the cost of materials and manufactured products that are to be purchased or produced by the Contractor under the Contract provisions.
- D. Any items that have been selected as "Specialty Items" for the Contract are listed as such in the Special Provisions, bid schedule, or elsewhere in the Contract Documents.
- E. No portion of the Contract shall be sublet, assigned or otherwise disposed of except with the written consent of the District contracting officer, or District's authorized representative, and such consent when given shall not be construed to relieve the Contractor of any responsibility for the fulfillment of the Contract. Request for permission to sublet, assign, or otherwise

dispose of any portion of the Contract shall be in writing and accompanied by:

- 1) a showing that the organization that will perform the work is particularly experienced and equipped for such work, and
- 2) an assurance by the Contractor that the labor standards provisions set forth in this Contract shall apply to labor performed on all work encompassed by the request.

#### **4. Prevailing Wage**

A bid shall not be accepted nor any contract or subcontract entered into without proof of the contractor and all subcontractor's current registration to perform public work pursuant to Section 1725.5 of the California Labor Code that states that a contractor (and all subcontractors) shall be registered with the California Department of Industrial Relations to be qualified to bid on this proposal subject to the requirements of Section 4104 of the Public Contract Code.

Compliance with General Prevailing Wage Determination made by the Director of Industrial Relations pursuant to California Labor Code for Commercial Building, Highway, Heavy Construction, and Dredging projects in Humboldt County, will be required. A copy of the Determination of the Prevailing Wage shall be posted at the project site. The Contractor shall provide Certified Payroll Records in accordance with Section 1720 through 1860 of the California Labor Code with each request for payment, or as requested by the District. The District may assess a fine in accordance with Section 1776 (g) of the Labor Code if the Contractor fails to provide such records within the time specified in the Code.

#### **5. Insurance Provisions**

- A. **Indemnification:** To the extent permitted by law, Contractor shall defend, indemnify, and hold harmless District, its directors, officers, employees, and authorized volunteers from and against all claims, damages, losses and expenses, including reasonable attorneys' fees and costs to defend arising out of the performance of the work described herein, and caused in whole or in part by any negligent act or omission of the Contractor, any subcontractor, anyone directly or indirectly employed by any of them, or anyone whose acts any of them may be liable, except where caused by the active negligence, sole negligence, or willful misconduct of the District, its directors, officers, employees, and authorized volunteers.
- B. **Minimum Scope and Limits of Insurance:** Contractor shall procure and maintain for the duration of the contract, and for 5 years thereafter, insurance against claims for injuries or death to persons or damages to property which may arise from or in connection with the performance of the work hereunder by the Contractor, his/her agents, representatives, employees, or subcontractors.
- C. **Insurance Coverage:** Coverage shall be at least as broad as the following:  
  
Coverage shall be at least as broad as the following:
  1. **General Liability - Commercial General Liability (CGL)** - Insurance Services Office (ISO) Commercial General Liability Coverage (Occurrence Form CG 00 01) including products and completed operations, property damage, bodily injury, personal and advertising injury with limit of at least five



million dollars (\$5,000,000) per occurrence or the full per occurrence limits of the policies available, whichever is greater. If a general aggregate limit applies, either the general aggregate limit shall apply separately to this project/location (coverage as broad as the ISO CG 25 03, or ISO CG 25 04 endorsement provided to Humboldt Community Services District) or the general aggregate limit shall be twice the required occurrence limit.

2. **Automobile Liability** - Insurance Services Office (ISO) Business Auto Coverage (Form CA 00 01), covering Symbol 1 (any auto) with limit of one million dollars (\$1,000,000) for bodily injury and property damage each accident.
3. **Workers' Compensation Insurance** - The Contractor shall provide workers' compensation coverage as required by the State of California, with Statutory Limits, and Employer's Liability Insurance with limit of no less than \$1,000,000 per accident for bodily injury or disease. **Waiver of Subrogation** (also known as Transfer of Rights of Recovery Against Others to Us): The Contractor hereby agrees to waive rights of subrogation to obtain endorsement necessary to affect this waiver of subrogation in favor of Humboldt Community Services District, its directors, officers, employees, and authorized volunteers, for losses paid under the terms of this coverage which arise from work performed by the Named Insured for Humboldt Community Services District; this provision applies regardless of whether or not Humboldt Community Services District has received a waiver of subrogation from the insurer.
4. **Builder's Risk** – (Course of Construction) if necessary - insurance utilizing an "All Risk" (Special Perils) coverage form with limits equal to the completed value of the project and no coinsurance penalty provision. See **Responsibility for Work (page 18)**.
5. **Contractor's Pollution Liability** – with limits no less than \$2,000,000 per occurrence or claim, and \$4,000,000 policy aggregate.

If the Contractor maintains broader coverage and or/higher limits than the minimums shown above, Humboldt Community Services District requires and shall be entitled to the broader coverage and/or higher limits maintained by the Contractor. Any available insurance proceeds in excess of the specified minimum of insurance and coverage shall be available to Humboldt Community Services District)

**Other Required Provisions** – The Commercial General Liability policy and Contractors Pollution (if necessary) are to contain, or be endorsed to contain, the following provisions:

1. **Additional Insured Status:** Humboldt Community Services District, its directors, officers, employees, and authorized volunteers are to be given insured status (at least as broad as ISO Form CG 20 10 11 85) or if not available, through the addition of **both** CG 20 10 10 01 and CG 20 37 10 01, with respect to liability arising out of work or operations performed by or on behalf of the Contractor including materials, parts, or equipment furnished in connection with such work or operations. General liability coverage can be provided in the form of an endorsement to the Contractor's insurance.
2. **Primary Coverage:** For any claims related to this project, the Contractor's insurance coverage shall be primary (at least as broad as ISO CG 20 01 04 13) with respect to Humboldt Community Services District, its directors, officers, employees, and authorized volunteers. Any insurance or self-insurance maintained by Humboldt Community Services

District, its directors, officers, employees, and authorized volunteers shall be excess of the Contractor's insurance and shall not contribute with it.

**Notice of Cancellation:** Each insurance policy required above shall provide that coverage shall not be canceled, except with notice to Humboldt Community Services District.

**Acceptability of Insurers** - Insurance is to be placed with insurers having a current A.M. Best rating of no less than A: VII or equivalent or as otherwise approved by Humboldt Community Services District. The Contractor agrees and he/she will comply with such provisions before commencing work. All of the insurance shall be provided on policy forms and through companies satisfactory to Humboldt Community Services District. Humboldt Community Services District reserves the right to obtain complete, certified copies of all required insurance policies, including the policy declarations page with endorsement number Failure to continually satisfy the Insurance requirements is a material breach of contract.

**Responsibility for Work** - Until the completion and final acceptance by Humboldt Community Services District of all the work under and implied by this agreement, the work shall be under the Contractor's responsible care and charge. The Contractor shall rebuild, repair, restore and make good all injuries, damages, re-erections, and repairs occasioned or rendered necessary by causes of any nature whatsoever.

The Contractor shall provide and maintain **builder's risk** (course of construction) or an installation floater (for materials and equipment) covering all risks of direct physical loss, damage or destruction to the work in the amount specified in the General Conditions, to insure against such losses until final acceptance of the work by Humboldt Community Services District. Such insurance shall insure at least against the perils of fire and extended coverage, theft, vandalism and malicious mischief, and collapse. The Policy shall be endorsed with Humboldt Community Services District, its directors, officers, employees, and authorized volunteers named as loss payee, as their interest may appear. The making of progress payments to the Contractor shall not be construed as creating an insurable interest by or for Humboldt Community Services District or be construed as relieving the Contractor or his/her subcontractors of responsibility for loss from any direct physical loss, damage or destruction occurring prior to final acceptance of the work by Humboldt Community Services District

**Deductibles and Self-Insured Retentions** - Insurance deductibles or self-insured retentions must be declared by the Contractor, and approved by Humboldt Community Services District. At the election of Humboldt Community Services District, the Contractor shall either cause the insurer to reduce or eliminate such self-insured retentions as respects Humboldt Community Services District, its directors, officers, employees, and authorized volunteers or the Contractor shall provide a financial guarantee satisfactory to the Humboldt Community Services District guaranteeing payment of losses and related investigations, claim administration, and defense expenses. The policy language shall provide, or be endorsed to provide, that the self-insured retention may be satisfied by either the named insured or Humboldt Community Services District.

**Verification of Coverage - Evidences of Insurance** Contractor shall furnish Humboldt Community Services District with copies of certificates and amendatory endorsements effecting coverage required by this contract. All certificates and endorsements are to be received and approved by Humboldt Community Services District before work commences. However, failure to obtain the required documents prior to the work beginning shall not waive the Contractor's obligation to provide them. Humboldt Community Services District reserves the right to require complete, certified copies of all required insurance policies, including

policy Declaration pages and Endorsement pages, required by these specifications, at any time. Failure to continually satisfy the Insurance requirements is a material breach of contract.

**Continuation of Coverage** - The Contractor shall, upon demand of Humboldt Community Services District deliver evidence of coverage showing continuation of coverage for at least (5) years after completion of the project. Contractor further waives all rights of subrogation under this agreement When any of the required coverages expire during the term of this agreement, the Contractor shall deliver the renewal certificate(s) including the general liability additional insured endorsement and evidence of waiver of rights of subrogation against Humboldt Community Services District (if builder's risk insurance is applicable) to Humboldt Community Services District at least ten (10) days prior to the expiration date.

**Sub-Contractors** - In the event that the Contractor employs other Contractors (sub-contractors) as part of the work covered by this agreement, it shall be the Contractor's responsibility to require and confirm that each sub-contractor meets the minimum insurance requirements specified above (via as broad as ISO CG 20 38 04 13). The Contractor shall, upon demand of Humboldt Community Services District, deliver to Humboldt Community Services District copies such policy or policies of insurance and the receipts for payment of premiums thereon.

**\*\* END OF SECTION \*\***

**This Page Left Intentionally Left Blank**

## **AWARD AND EXECUTION OF CONTRACT**

### **1. Award of Contract**

The award of the Contract, if it is awarded, will be to the lowest responsive, responsible bidder whose proposal complies with all the requirements prescribed. The District, in accordance with the provisions of Title VI of the Civil Rights Act of 1964 (78 Stat. 252) and the Regulations of the Department of Commerce (15 CFR, Part 8), issued pursuant to such act, hereby notifies all bidders that it will affirmatively ensure that the Contract entered into pursuant to this advertisement will be awarded to the lowest responsible bidder without discrimination on the ground of race, color, or national origin. The District Board, however, reserves the right to reject any or all bids, and to waive any informality or irregularity in bids received. The District Board also reserves the right to reject the bid of any bidder who has previously failed to perform properly or did not complete on time contracts with the District, of a nature similar to this project. Such award, if made, will be made within sixty (60) days after the opening of the proposals. All bids will be compared on the basis of the engineer's estimate of the quantities of work to be done.

### **2. Contract Bonds**

The general form of the bonds that the Contractor will be required to furnish at the time of execution of the agreement are included in the Contract Documents and should be carefully examined by the bidder. The bonds will be executed in triplicate original counterparts.

### **3. Failure to Execute Contract**

Failure to execute a contract and file acceptable bonds as provided herein within eight (8) days, not including Sundays, after the bidder has received notice that the Contract has been awarded, shall be just cause for forfeiture of Contractor's proposal guaranty to the District. If the successful bidder refuses or fails to execute the Contract, the District Board may award the Contract to the second lowest responsible bidder. If the second lowest responsible bidder refuses or fails to execute the Contract, the Board may award the Contract to the third lowest responsible bidder. On the failure or refusal of the second or third lowest responsible bidder to whom any such Contract is so awarded to execute the same, such bidder's guaranties shall be likewise forfeited to the District. The work may then be re-advertised or may be constructed by day labor, as the District Board may decide.

### **4. Execution of Contract**

The Contract shall be signed by the successful bidder and returned, together with the Contract bonds and satisfactory evidence of insurance as provided in this section, within eight (8) days, not including Sundays, after the bidder has received notice that the Contract has been awarded. No proposal shall be considered binding upon the District until the execution of the Contract.

### **5. Return of Proposal Guaranties**

Upon the award to the lowest responsible, responsive bidder, the proposal guarantees of unsuccessful bidders shall be returned within 60 days of the time the award is made.

## 6. Insurance

### A. **General Liability**

The Contractor shall take out and maintain, throughout the period of this Contract, comprehensive general liability insurance with minimum limit of at least \$5,000,000 per occurrence or the full per occurrence limits of the policies, whichever is greater covering all bodily injury and property damage arising out of its operation under this agreement. Refer to General Conditions Section 5.C.1 for more details.

### B. **Automobile**

The Contractor shall provide automobile insurance covering all bodily injury and property liability incurred during the performance of this Contract with minimum coverage of \$1,000,000.00 for bodily injury or property damage per accident. Refer to General Conditions Section 5.C.2 for more details.

### C. **Contractors Pollution Liability**

The Contractor shall take out and maintain, throughout the period of this Contract, contractor's pollution liability insurance with a limit no less than \$2,000,000 per claim or occurrence and \$4,000,000 policy aggregate. Refer to General Conditions Section 5.C.5 for more details.

### D. **Worker's Compensation**

The Contractor shall, throughout the period of this Contract, maintain in full force and effect a policy of worker's compensation insurance covering all its employees and volunteers. Refer to General Conditions Section 5.C.3 for more details.

### E. **Additional Insured Notices**

Said policies shall name the District as an additional insured and shall constitute primary insurance as to the District, its officers, agents, and employees, so that any other policies held by the District shall not contribute to any loss under said insurance. Said policies shall provide for thirty (30) days prior written notice to the District of cancellation or material change.

### F. **Encroachment Permit Insurance Requirements**

The Contractor shall additionally provide the County of Humboldt all insurance requirements as outlined in the permit.

G. The District shall not execute this Contract until certificates, or other sufficient proof that these insurance provisions have been complied with, are filed with the District. If the Contractor does not keep such insurance in full force and effect, the District may take out the necessary insurance, and the Contractor agrees to pay the cost of said insurance or the Contractor shall be deemed as having failed to execute the work.

**\*\*END OF SECTION\*\***

**PROPOSAL TO THE BOARD OF DIRECTORS**  
**OF THE HUMBOLDT COMMUNITY SERVICES DISTRICT FOR**

**Doctor's Office Lane Sewer Rehabilitation Project**

To the District Board of Directors:

The undersigned, as Bidder, declares that the only persons or parties interested in this proposal as principals are those named herein; that this proposal is made without collusion with any other person, firm or corporation; that Bidder has carefully examined the location(s) of the proposed work and the proposed form of the Contract and the Plans and Specifications; and Bidder agrees if this proposal is accepted, that Bidder will Contract with the District, in the form of the Contract annexed hereto, to provide all necessary machinery, tools, apparatus, and other means of construction, and to do all the work and furnish all the materials specified in the Contract in the manner and time prescribed and according to the requirements of the District; that Bidder will provide the bonds as required herein at the time Bidder executes the Contract; that Bidder will provide proof of insurance as provided herein; that Bidder will provide HCSD with a construction schedule within **10 working days** after receiving notice from the District to proceed, and diligently prosecute the same to completion within **50 consecutive working days (excluding weekends and holidays)** contained in a construction window **beginning April 1, 2025 terminating October 31, 2025**. As provided for in the Notice to Contractors the liquidated damage shall be in the sum of One Thousand dollars (\$1,000.00) per day for each and every working days delay in finishing the work beyond the time described herein, and that Bidder will take in full payment therefore the following unit or lump sum prices, as the case may be, to wit:

Bidder Signature: \_\_\_\_\_

Company: \_\_\_\_\_

**\*\*\* BIDDER MUST SIGN THIS PAGE \*\*\***

**This Page Left Intentionally Left Blank**



**Bid Schedule**

**Attachment B**

**Doctor's Office Lane Sewer Rehabilitation Project**

Bid Item No.	Approx. Quantity	Unit	Bid Item Description	Unit Price	Total Item Price
1.	1	Lump Sum	Mobilization/Demobilization	\$ <u>N/A</u>	\$ _____
2.	1	Lump Sum	Traffic Control	\$ <u>N/A</u>	\$ _____
3.	250 Feet	Lump Sum	6" Sewer Main PVC Lining	\$ <u>N/A</u>	\$ _____
4.	85 Feet	Lump Sum	6" PVC Sewer Main Installation	\$ <u>N/A</u>	\$ _____
5.	100 Feet	Lump Sum	4" HDPE Sewer Lateral Installation	\$ <u>N/A</u>	\$ _____
6.	2	Each	Manhole Installation	\$ <u>N/A</u>	\$ _____
Subtotal Base Bid Items No. 1-6					\$ _____

**Additive Bid Item(s)**

\* Note: Items 8-13 are included in the event that in-field quantities exceed those listed in the approved plan set.

Bid Item No.	Approx. Quantity	Unit	Bid Item Description	Unit Price	Total Item Price
7.	1	Per Day	Additional Traffic Control	\$ _____	\$ <u>N/A</u>
8.	1	Per Linear Foot	Additional Sewer Main PVC Lining	\$ _____	\$ <u>N/A</u>
9.	1	Per Linear Foot	Additional Sewer Main Installation	\$ _____	\$ <u>N/A</u>
10.	1	Per Linear Foot	Additional Sewer Lateral Installation	\$ _____	\$ <u>N/A</u>
11.	1	Per Cubic Yard	Additional Earthwork	\$ _____	\$ <u>N/A</u>
12.	1	Per Square Yard	Additional Paving	\$ _____	\$ <u>N/A</u>

Subtotal Additive Bid Items No. 7-12	\$ _____
--------------------------------------	----------

Subtotal Base Bid Items No. 1-6	\$ _____
Subtotal Additive Bid Items No. 7-12	\$ _____
Total Bid (Base + Additive)	\$ _____

-----  
Signature of Bidder

-----  
Company

**\*\*\* BIDDER MUST SIGN THIS PAGE \*\*\***

**Note:** See "Section 01 22 00: Measurement and Payment" for a detailed description of each bid item

It is further understood and agreed that:

- (a) In case of a discrepancy between unit prices and totals, the unit price shall prevail.
- (b) The District reserves the right to eliminate any section of this proposal from the Contract without claim of the Contractor for profits lost.
- (c) No verbal agreement or conversation with any officer, agent, or employee of the District, either before or after the execution of the Agreement, shall affect or modify any of the terms or obligations of this proposal.
- (d) The District will not be responsible for any errors or omissions on the part of the undersigned in making up their bid, nor will the Bidder be released on account of errors.
- (e) The undersigned Bidder is properly licensed in accordance with the State of California Act providing for the registration of Contractors.
- (f) If the proposal shall be accepted and the undersigned shall fail to contract as aforesaid and to give the two bonds in the sums to be determined as aforesaid, with surety satisfactory to the District Board, within EIGHT (8) CALENDAR DAYS (not including Sundays) after the Bidder has received notice from the District Board that the Contract is ready for signature, the District Board may, at its option, determine that the Bidder has abandoned the Contract, and thereafter this proposal and the acceptance thereof shall be null and void, and the forfeiture provisions relating to such security accompanying this proposal shall operate, and the said security shall be the property of the District.
- (g) The undersigned Bidder certifies that he/she has confirmed that the proposed form of Contract and the Plans and Specifications are complete.

----- Date	----- Bidder Name
----- Authorized Signature	----- Type of Organization
----- Telephone Number	----- Email Address
----- Bidder Address	----- State Contractors License No. and Expiration Date

The above signed acknowledges that these representations are made under penalty of perjury.

**This Page Left Intentionally Left Blank**

**AGREEMENT**

This Agreement, made the \_\_\_\_ day of \_\_\_\_\_ in the year 202\_\_, by and between the HUMBOLDT COMMUNITY SERVICES DISTRICT, a California public entity (hereinafter "Owner") and \_\_\_\_\_, a California \_\_\_\_\_ (hereinafter "Contractor"), is for performance of the work on the following work of improvement:

Project Name and Address:	Doctor's Office Lane Sewer Rehabilitation Project 2800 Harris Street
Project Owner and Address:	Humboldt Community Services District 5055 Walnut Drive, Eureka CA 95503
Project Engineer and Address:	Whitchurch Engineering 716 Harris Street, Eureka CA 95503

Contractor's business is a \_\_\_\_\_.

Contractor's Federal Tax I.D. # or S.S. # \_\_\_\_\_.

In consideration of the sums herein agreed to be paid and the terms, conditions and covenants to be performed by the parties, it is agreed as follows:

Contractor agrees to furnish all material, labor, tools, equipment, services, information, documents, permits, and instruction and parts manuals therefor, and to do and complete, in a workmanlike manner and as directed by and to the satisfaction of Owner, all work hereinafter described for that certain project, more particularly described in the Contract Documents (defined in Section 1.1, below) (the "Work").

**ARTICLE 1 – CONTRACT DOCUMENTS**

**1.1 CONTRACT DOCUMENTS DEFINITION.** The Contract Documents consist of this Agreement and all attachments and exhibits thereto (including **Attachment A** which references the Project Plans and Specifications and **Attachment B** which is Contractor's bid response and **Attachment C** which include the insurance requirements), and all changes and modifications to the Contract Documents, the latest adopted edition of the Uniform Building Code, Fire Code, and Mechanical Code, the Uniform Standard Specifications for Public Works Construction, and all applicable laws, rules, ordinances, and regulations, California Labor Code, the California

Business and Professions Code, the California Public Contract Code, and the Federal Acquisition Regulations. The Contract Documents are complementary and what is required by one shall be as binding as if required by all.

**1.2 CONTRACTOR SHALL BIND SUBCONTRACTORS TO SAME EXTENT AS CONTRACTOR.** If Contractor contracts with any subcontractor(s) to perform any part of the Work on this Project, Contractor shall be responsible to ensure that each subcontractor shall assume toward Contractor the obligations and responsibilities that Contractor assumes toward Owner insofar as they relate in any way, directly or indirectly, to the Work covered by this Agreement, including, without limitation, any terms and provisions for indemnity, insurance, warranties, and liquidated damages. Contractor shall bind lower tier subcontractors and suppliers to full compliance with all Contract Documents, including all performance obligations and responsibilities that Contractor assumes toward Owner.

## **ARTICLE 2 – DESCRIPTION OF WORK**

**2.1 CONTRACTOR’S WORK.** Contractor, as an independent contractor, shall furnish all labor and materials, equipment, and services as are necessary to perform all of the Work required by, or reasonably inferable from, the Contract Documents unless specifically excluded herein. Contractor’s work shall be completed in a workmanlike manner in strict conformity with the Contract Documents and to the satisfaction of Owner.

**2.2 REPRESENTATION THAT CONTRACT DOCUMENTS ARE COMPLETE.** Contractor has reviewed the Contract Documents and represents: (1) if the Contractor’s work is performed in accordance therewith, it shall comply with all applicable state, county, and municipal laws, codes, and regulations, including but not limited to all building codes; and (2) the Contract Documents are sufficiently complete to permit Contractor to perform its work, in its entirety, on the basis of the Contract Documents and matters reasonably inferable therefrom for the Agreement Price set forth in Article 3 below.

**2.3 SUBCONTRACT/ASSIGNMENT.** Contractor shall not subcontract, assign, transfer, or sublet any portion of its Work or the proceeds for Contractor’s work without the prior written consent of Owner. Any such assignment shall not relieve Contractor from any obligations or liabilities under the Agreement and the assignee shall take the assignment subject to all rights of Contractor herein provided.

Contractor shall be fully responsible to Owner for the acts and omissions of its lower-tier subcontractors and of persons or entities, either directly or indirectly, employed by all of Contractor’s lower-tier subcontractors. This Agreement shall not be transferable by Contractor or by operation of law. If requested by Owner, Contractor shall furnish Owner a copy of any

proposed contract or agreement between Contractor and any of its lower-tier subcontractors for Owner's review of the terms and conditions thereof, and Contractor shall not execute such agreement until Owner has given written notice of Owner's approval. Failure of Contractor to comply with this Article may be deemed to be a material breach of the Agreement and grounds for Owner to withhold payment therefor. Contractor guarantees that all lower-tier subcontractors will strictly comply with the terms of this Agreement, which shall be expressly incorporated by reference into any contract or agreement with any of Contractor's lower-tier subcontractors.

**2.4 DISPUTED WORK.** In the event of any dispute between Owner and Contractor over the scope of Contractor's work under the Contract Documents, Contractor will not stop work, but will prosecute the work, including as directed by Owner, diligently to completion, and any such dispute shall be submitted to resolution in accordance with this Agreement.

### **ARTICLE 3 – PRICE AND SCHEDULE OF VALUES**

**3.1 CONTRACT PRICE.** The sum to be paid by Owner to the Contractor for the performance and completion of the Agreement to the satisfaction of Owner, inclusive of the duties, obligations and responsibilities of the Contractor under this Agreement and the other Contract Documents, and subject to any additions or deductions as authorized under this Agreement shall be as set forth in Contractor's bid schedule attached hereto as ***Bid Schedule*** ("Contract Agreement Price" or "Price"). The total project cost shall not exceed the total amount for the entirety of the Work set forth in ***Attachment A*** (i.e., \$ \_\_\_\_\_), unless otherwise authorized by Owner in writing prior to Contractor incurring additional expenses.

The Price shall constitute payment in full for all amounts owed to Contractor, including but not limited to the costs incurred for: all labor (including fringe benefit payments), materials, supplies, apparatuses, appliances, equipment, fixtures, tools, implements, facilities, supervision, transportation, utilities, storage, and all other services as and when required for or in connection with the performance of Contractor's work, business licenses, Social Security, employment, sales, use, state, federal, and all other taxes, continuous clean-up, final clean-up, and all insurance required by the Agreement and the other Contract Documents.

**3.2 USE OF FUNDS.** Contractor agrees and covenants that funds received for the performance of this Agreement shall be used solely for the benefit of persons and firms supplying labor, materials, supplies, tools, machines, equipment, plant or services exclusively for this Project in connection with this Agreement and having the right to assert liens or other claims against the land, improvements or funds involved in this Project or against any bond or other security posted by Contractor or Owner, and said funds shall not in any instance be

diverted by Contractor to any other purpose until all obligations arising herein have been fully discharged and all claims arising therefrom have been fully paid.

#### **ARTICLE 4 – PAYMENT**

**4.1 PROGRESS PAYMENTS.** Based on the Invoices (as defined in section 4.2 below), and upon acceptance of same by Owner, which shall not be unreasonably withheld, the Owner shall make progress payments on account of the Contract Price to Contractor. The period covered by each Invoice shall be one (1) calendar month ending on the last day of the month, as follows:

**4.1.1** Provided that an Invoice is received by the Owner not later than the 5th day of a month, and subject to Contractor's compliance with the requirements described in sections 4.2 and 4.3 below, and subject to Owner's acceptance of the Invoice, the Owner shall make payment of the Invoice amount no later than the last day of the same month. If an Invoice is received by the Owner after the Invoice date fixed above, payment of the amount accepted by Owner shall be made not later than 30 calendar days after the Owner receives the Invoice from the Contractor.

**4.1.2** Each Invoice shall be based on the most-recent Schedule of Values submitted by the Contractor and approved by Owner in accordance with the Contract Documents. The Schedule of Values shall allocate the entire Contract Price among: (1) the various portions of the Work; (2) any contingency for costs that are included in the Contract Price but not otherwise allocated to another line item or included in a Change Order; and (3) the Contractor's Fee.

**4.1.3** The Schedule of Values shall be prepared in such form and supported by such data to substantiate its accuracy as the Owner may reasonably require. The Schedule of Values shall be used as a basis for reviewing Contractor's Invoices.

**4.2 SUBMISSION OF INVOICES.** By such date as directed by Owner, Contractor shall submit to Owner for Owner's approval a written request for payment ("Invoice") in an approved form showing the proportionate value of the work performed and completed to date, allocated among the appropriate line items in Contractor's approved Schedule of Values (if applicable), and as required by the Contract Documents. All invoices must be dated and signed by Contractor and include deductions for: (a) retention of 5% of the value of the work or as stated in the Contract Documents; (b) all previous payments; (c) all charges for materials and services furnished to Contractor by Owner; (d) back charges by any other subcontractor or material



supplier; and (e) any other charges and deductions provided for in this Agreement. Contractor shall submit revised invoices until accepted by Owner, which shall not unreasonably be withheld.

**4.3 WAIVERS AND RELEASES.** As a condition precedent to payment by Owner, the Invoice shall be accompanied by a current Conditional Waiver and Release Upon Progress Payment, in the form specified by California Civil Code section 8132, from Contractor and each of Contractor's subcontractors, suppliers, and union trust funds for which payment is sought by the Invoice, and an Unconditional Waiver and Release Upon Progress Payment, in the form specified by California Civil Code section 8134, from Contractor and each of Contractor's subcontractors, suppliers, and any union trust fund for which payment was sought by Contractor and for which Contractor made payment.

**4.4 CERTIFIED PAYROLL AND AFFIDAVITS.** As an additional condition precedent to payment by Owner, Contractor shall provide, within the time limits specified by the Contract Documents, certified payroll reports certifying that all labor included in the Invoice was paid pursuant to the applicable prevailing wage rates. Contractor shall also submit an affidavit, signed under penalty of perjury, certifying that it has paid for all labor (including fringe benefits), materials and equipment for which Owner has made payment to Contractor.

**4.5 PAYMENT NOT ACCEPTANCE.** Payment to Contractor shall not constitute or imply acceptance by Owner of any portion of Contractor's work or the full performance thereof.

**4.6 PAYMENT IN THE EVENT OF DISPUTE AS TO CONTRACTUAL REQUIREMENTS.** In the event a dispute arises between Contractor and/or Owner as to the work to be performed by Contractor, Contractor shall receive payment for its work according to the provisions and requirements of the Agreement as though they are a contended by Contractor and/or Owner. Contractor shall not be entitled to additional compensation for work it contends is outside the scope of the Agreement unless and until the dispute is resolved in its favor.

**4.7 REQUIREMENTS FOR PAYMENT.** As a condition precedent to Contractor's obligation to make payment, Contractor shall:

- (a) Submit an affidavit, under penalty of perjury, that all payroll, payroll taxes, fringe benefits, bills for material and equipment, and other indebtedness connected with Contractor's work for which Owner and/or any surety might in any way be liable, have been paid or otherwise satisfied;
- (b) Submit conditional and unconditional waivers upon final payment in accordance with Civil Code sections 8136 and 8138;

- (c) Comply with all required close-out procedures to the satisfaction of Owner.

Within ten (10) days of Contractor's receipt of final payment, it shall provide to Owner an Unconditional Waiver and Release Upon Final Payment, in the form required by California Civil Code section 8138.

**4.8 FINAL PAYMENT.** Provided Contractor is not in default under the Agreement; there is no dispute between Contractor and Owner regarding Contractor's work; Owner and, if necessary, the Project Engineer, have accepted the Project; and Owner has received Contractor's release(s) of all claims related to Contractor's work except for unsettled liens or stop notices, unknown defective work, noncompliance with the Contract Documents, or warranty work, **final payment** shall be made no more than 10 (ten) calendar days after Contractor's compliance with the conditions for payment.

**4.9 WITHHOLDING.** Owner may withhold any and all payments due Contractor hereunder in order to protect itself from loss on account of Contractor and/or as may reasonably be necessary to protect Owner from loss or damage caused by Contractor, including but not limited to withholdings applicable to Contractor's work arising from grounds enumerated in the Contract Documents, Contractor's failure to perform Contract Work, breach of this Agreement, failure to properly pay employees, subcontractors and/or suppliers, failure to promptly correct rejected, defective or nonconforming Contract Work, and any other matter as to which this Agreement specifically authorizes the withholding by Owner of such payment, including Contractor's failure to comply with the requirements of the Contract Documents.

## **ARTICLE 5 – CHANGES**

**5.1 DIRECTED IN WRITING.** Owner may order or direct changes, additions, deletions or other revisions to the Work without invalidating the Agreement. No changes, additions, deletions, or other revisions to the Work shall be valid unless made in writing. If Contractor performs additional work or revises the Work without written direction from Owner, Contractor shall not be paid for any additional labor, materials, or supplies furnished and shall be liable for any and all losses, costs, expenses, damages, and liability of any nature whatsoever associated with or in any way arising out of any such change.

**5.2 PRICE ADJUSTMENTS.** If Owner directs a material change to the Work pursuant to Section 5.1 of this Agreement, the Price stated in Article 3 and the time for Contractor's performance shall be adjusted by appropriate additions or deductions in accordance with the Agreement. Contractor shall supply Owner with all documentation necessary to substantiate the amount of the addition to or deduction from the Price or Contractor's time for performance.

Any request of Contractor for an addition to or deduction from the Price, or Contractor's time for performance, must be made to Owner in itemized written form (accompanied by complete documentation substantiating any request(s)) within seven (7) calendar days from the date of receipt by Contractor of notification of change. In the event Owner and Contractor cannot agree on the amount of the addition or deduction, Contractor shall nonetheless perform the work as changed by Owner's written direction. Once Contractor receives Owner's written direction, Contractor is solely responsible for timely performance of the Work as changed by the written direction. Payment for changed Work shall be made in accordance with Article 4.

**5.3 NOTICE OF DISPUTED WORK.** If a dispute arises between Owner and Contractor about whether a particular work is a change in the Work described in Article 2, Contractor shall timely perform the disputed work and may give written notice of a claim for additional compensation for that work all in accordance with the Contract Documents. Such written notice of claim must be given prior to the performance of the disputed work, and no later than the notice periods set forth in Article 12, below. Contractor's failure to give written notice prior to the performance of the disputed work constitutes an agreement by Contractor that it will not be paid for the disputed work.

## **ARTICLE 6 – TIME OF COMPLETION AND SCHEDULE**

**6.1 TIME IS OF ESSENCE.** Time limits stated in the Contract Documents are of the essence of the Agreement. By executing the Agreement, Contractor confirms that the contract time is sufficient for performing Contractor's work.

**6.2 CONTRACT TIME.** Contract Time for completion of all work is 50 Consecutive Days Between April 1, 2025 and October 31, 2025, unless extended by written agreement of the parties hereto or in the event the Contract Time is extended pursuant to Section 6.4 below.

**6.3 SCHEDULE OF WORK.** Contractor shall have the right to decide the time and order in which the various portions of the Work are to be performed, including the relative priority of the work of subcontractors. Contractor shall prepare the Schedule of Work and shall revise the Schedule of Work as work progresses.

**6.4 CONTRACTOR'S RESPONSIBILITIES.** Contractor shall commence work on the Project within five (5) calendar days of receiving a written Notice to Proceed from the Owner. Contractor shall complete the work in the time set forth in Section 6.2, subject to permissible delays. Permissible delays are acts of God, war, war defense, riots, litigation, acts of the Owner or the Owner's agent, employee, or independent contractor, stormy weather, strikes, walkouts, acts of public utilities, public bodies or inspectors, extra work, failure of Owner to make payments promptly, the time involved in preparing and

negotiating agreed Change Orders if such delays actually impact the critical path of the Project so as to cause delay, failure of Owner to authorize Change Orders in a timely fashion so as to delay schedule, failure of Architect to provide requested information or clarification in a manner which does not delay the schedule or other contingencies unforeseeable by or beyond the reasonable control of the Contractor. In the event of delay, Contractor shall notify Owner in writing within three (3) days of the occurrence and cause of delay and the estimated number of days the delay Contractor anticipates will occur. Contractor's failure to notify Owner shall result in no extension of time for completion. If at any time Owner wishes the Project to be completed in less time than set forth above, with any permissible delays, such acceleration in work shall be deemed a request for extra work, as forth herein and accomplished only pursuant to written Change Order.

**6.5 CONTRACTOR'S REMEDIES FOR DELAY.** If the progress of Contractor's work is delayed without the fault or responsibility of Contractor, then the time for Contractor's work shall be extended by change order to the extent obtained by from Owner and the Schedule of Work shall be revised accordingly. On projects subject to the Public Contract Code, the provisions of section 7102 shall apply; however, Owner and Contractor expressly contemplate and acknowledge that if the Work is enjoined by a court of law or a bid protest of any type or nature is asserted which delays the performance of the Work, Owner shall have no liability or responsibility to Contractor for any delay damages.

**6.6 OWNER'S REMEDIES FOR DELAY.** In the event that the completion of the Project is delayed beyond the time specified in the Contract Documents due to the fault of Contractor, and the delay is not otherwise excused, then the Contractor shall pay to the Owner the sum of One-Thousand Dollars (\$1,000.00) per day as liquidated damages for each calendar day during which completion of the Project is delayed beyond the time specified for completion. The Parties acknowledge that calculation and proof of actual damages due to such delays are difficult to estimate on the date this agreement is made, and that the provisions made herein are a fair and good faith estimate of actual damages Owner may suffer in the event of such delays. This provision is not intended to constitute a penalty clause.

## **ARTICLE 7 – TERMINATION OR SUSPENSION**

**7.1 TERMINATION FOR CONVENIENCE.** Notwithstanding any other provision of the Agreement, Owner reserves the right to terminate this Agreement for Owner's convenience, without cause. If so terminated, Contractor shall be entitled to the following costs and no others: cost of Work actually completed in conformity with the requirements of the Agreement and Contract Documents; other necessary costs actually incurred by Contractor; plus fifteen percent (15%) of such costs as overhead and profit.

**7.2 SUSPENSION OR TERMINATION BY OWNER.** Should the Owner suspend or

terminate any aspect of the work, then Contractor shall immediately discontinue work upon written order from Owner. Contractor shall proceed with such work when ordered to do so by Owner.

## **ARTICLE 8 – PERFORMANCE OF CONTRACTOR**

**8.1 AUTHORIZED REPRESENTATIVE.** Contractor shall designate one or more persons satisfactory to Owner and with authority to act for Contractor as Contractor’s representative on-site and off-site. Such authorized representative(s) shall be the only person(s) to whom Owner shall issue instructions, orders or directions, except in an emergency. Should Owner find Contractor’s representative(s) to be unsatisfactory, Contractor shall promptly replace the representative(s).

**8.2 NON-DISCRIMINATION.** Contractor shall not discriminate in hiring, firing, promotion, or training against any person on account of age, race, religion, national origin, disability, sexual orientation, gender, or gender identity.

**8.3 SAFETY.** In the performance of this Agreement, Contractor shall comply with all applicable federal, state and local statutory and regulatory requirements including, but not limited to California Department of Industrial Relations (Cal/OSHA) regulations; and the U.S. Department of Transportation Omnibus Transportation Employee Testing Act, related to their scope of work and operations. In case of conflict in regulations, the most stringent shall apply. Contractor shall provide all safeguards, safety devices and protective equipment and take any other needed actions necessary to protect the life and health of employees on the job and the safety of the public and to protect property in connection with the performance of the work covered by the contract. Safety precautions shall include but shall not be limited to: adequate life protection and lifesaving equipment; adequate illumination; instructions in accident prevention for all employees, such as the use of machinery guards, safe walkways, scaffolds, ladders, bridges, gang planks, confined space procedures, trenching and shoring, fall protection, and other safety devices; equipment and wearing apparel as are necessary or lawfully required to prevent accidents, injuries, or illnesses (including but not limited to exposure to the Coccidioides fungus and Valley Fever); and adequate facilities for the proper inspection and maintenance of all safety measures.

Contractor must obtain all applicable Division of Occupational Safety and Health (CAL-OSHA) permit(s) and others required by California Labor Code and California Government Code, prior to the initiation of any practices, work, method, operation, or process related to the work covered in the contract. Permits required by governmental authorities will be obtained at Contractor’s expense.

It is a condition of this Agreement, and shall be made a condition of each subcontract which Contractor enters into pursuant to this Agreement, that the Contractor

and any subcontractor shall not permit any employee, in performance of the contract, to work in surroundings or under conditions which are unsanitary, hazardous or dangerous to his/her health or safety, as determined under Cal/OSHA safety and health standards.

Contractor shall be responsible for the safeguarding of all utilities. At least two working days before beginning work, Contractor shall call the Underground Service Alert (USA) in order to determine the location of sub-structures. Contractor shall immediately notify Owner if Contractor disturbs, disconnects, or damages any utility.

In accordance with Section 6705 of the California Labor Code, Contractor shall submit to Owner specific plans to show details of provisions for worker protection from caving ground during excavations of trenches of five feet or more in depth. The excavation/trench safety plan shall be submitted to and accepted by Owner prior to starting excavation. The trench safety plan shall have details showing the design of shoring, bracing, sloping or other provisions to be made for worker protection from the hazard of caving ground. If such a plan varies from the shoring system standards established by the Construction Safety Orders of the California Department of Industrial Relations (Cal/OSHA), the plan shall be prepared by a California registered civil or structural engineer. As part of the plan, a note shall be included stating that the registered civil or structural engineer certifies that the plan complies with the Cal/OSHA Construction Safety Orders, or that the registered civil or structural engineer certifies that the plan is not less effective than the shoring, bracing, sloping or other provisions of the Safety Orders. In no event shall Contractor use a shoring, sloping, or protective system less effective than that required by said Construction Safety Orders. Submission of this plan in no way relieves Contractor of the requirement to maintain safety in all areas. If excavations or trench work requiring a Cal/OSHA permit are to be undertaken, Contractor shall submit its permit with the excavation/trench work safety plan to Owner before work begins.

**8.4 SHOP DRAWINGS, SAMPLES, AND AS-BUILT DRAWINGS.** By such date as directed by Owner, Contractor shall prepare and submit to Owner all shop drawings, samples, specimens, or other data necessary to completely describe Contractor's work and as required by the Contract Documents. Approval of such shop drawings, samples, specimens, or other data by Owner or the Architect shall not relieve Contractor of its responsibility to perform Contractor's work in strict accordance with the Contract Documents or of its responsibility for the proper matching and fitting of Contractor's work with contiguous work. Contractor shall also furnish all information required for the coordination of Contractor's work with the work of other trades. Contractor shall be responsible for preparing all as-built drawings pertaining to Contractor's work and as required by the Contract Documents.

**8.5 SUBSTITUTIONS.** Requests for substitution of material will be allowed only if permitted by the Contract Documents. Requests for substitution must be submitted in the format specified by the Contract Documents and submitted to Owner within a reasonable timeframe as directed by Owner or they may be returned without review. Architect may charge to review requests for substitution, whether approved or rejected, and all such costs shall be the responsibility of Contractor.

**8.6 PLAN INCONSISTENCY AND CONTIGUOUS WORK.** Contractor shall bring any uncertainty or inconsistency in or between the plans, specifications, or other Contract Documents to the attention of Owner in writing and within three (3) working days of Contractor's discovery thereof. Contractor shall not proceed with any Work affected by the uncertainty or inconsistency until directed to do so by Owner. Owner shall resolve the uncertainty or inconsistency and Contractor shall perform the work as directed by Owner.

Before proceeding with its work, Contractor shall inspect the correctness of contiguous or adjacent work installed by others. The failure to detect or report discrepancies will preclude recovery by Contractor of any resulting cost, expense, or damage.

**8.7 PROTECTION OF THE WORK.** Contractor shall take all necessary precautions to properly protect Contractor's work and the work of others from damage caused by Contractor's operations. Should Contractor cause damage to the Work or property of Owner or others, Contractor shall promptly remedy such damage to the satisfaction of Owner.

**8.8 INSPECTION.** When portions of Contractor's work are ready for inspection, Contractor shall notify Owner in writing in sufficient time to allow Owner to notify the inspecting authorities that the work is ready for inspection. Failure to properly and timely make notice of, or receive, required inspections is not cause for delay. Contractor shall at all times furnish Owner with adequate facilities for inspecting materials at the site or at any place where materials under this Agreement may be in the course of preparation, processing, manufacture or treatment.

**8.9 CLEAN-UP.** Contractor shall follow Owner's clean-up directions and shall at all times keep the Project free from debris and unsafe working conditions arising from Contractor's work. At the end of each day, Contractor shall consolidate its debris at a place designated by Owner and shall remove its debris from the job site immediately upon completion of each phase of Contractor's work or as directed by Owner. Contractor is to leave all areas where it is performing work in broom clean condition at the end of each work day. If work areas are not kept neat and safe at all times, Owner will back-charge Contractor as needed at an hourly rate of \$100.00 plus dump fees and all other necessary costs incurred by Owner.

**8.10 LABOR RELATIONS.** Contractor shall take reasonable steps to prevent the occurrence of any strike, slowdown, or other labor difficulty or dispute arising out of the presence of Contractor at the job site or from any other activities of Contractor.

Contractor acknowledges the provisions of the California Labor Code regarding the payment of prevailing wages to workers employed on public works projects. In compliance with the requirements of Labor Code section 1775(b)(1), Contractor acknowledges the existence and content of Part 7, Chapter 1 of the California Labor Code, including, without limitation, Labor Code sections 1771, 1775, 1777.5, 1813, and 1815, as incorporated herein by reference, and has read and understands the provisions of these code sections.

Contractor shall work with and respond to all requests for information related to labor code compliance by Owner and/or Owner's labor compliance specialist.

**8.11 WARRANTY.** Contractor warrants all materials, equipment, and workmanship provided under this Agreement for a period of one (1) year from completion of the entire Project or such longer period as may be provided in the Contract Documents. Contractor warrants to Owner that materials and equipment furnished under the Agreement will be of good quality and new unless otherwise required or permitted by the Contract Documents, that Contractor's work will be free from defects not inherent in the quality required or permitted, and that Contractor's work will conform to the requirements of the Contract Documents. Contractor shall furnish satisfactory evidence as to the kind and quality of materials and equipment, if requested by Owner to do so.

Work not conforming to these requirements, including substitutions not properly approved and authorized, may be considered defective. Contractor shall promptly amend and make good any defective materials, equipment, or workmanship to the approval and acceptance of Owner.

**8.12 PROJECT TO BE KEPT FREE OF LIENS.** Contractor shall promptly pay all subcontractors, suppliers, and others from payment received by Owner. In the event a subcontractor, material supplier, labor union trust fund, or other person or entity that supplied labor, material, or equipment to Contractor shall record/file a mechanic's lien or stop notice, Contractor shall, within two (2) working days of receipt of notice of said lien or stop notice, supply evidence to the satisfaction of Owner that the monies owing to the claimant have been paid or post a bond indemnifying Owner and the Project from such claim or lien.

**8.13 ROYALTIES, PATENTS AND COPYRIGHTS.** Contractor shall pay all royalties and



license fees, shall defend suits or claims for infringement of copyrights and patent rights, and shall hold Owner harmless from loss on account thereof. Contractor shall not be responsible for such defense or loss when a particular design, process or product of a particular manufacturer is required by the Contract Documents or where the copyright violations are contained in the Contract Documents.

**8.14 DISCOVERY OF HAZARDOUS WASTE OR UNUSUAL CONDITIONS.** Contractor shall promptly, and before the following conditions are disturbed, notify Owner, in writing, of any of the following conditions: (a) material that Contractor believes may be material that is hazardous waste, as defined in Section 25117 of the Health and Safety Code, that is required to be removed to a Class I, Class II, or Class III disposal site in accordance with provisions of existing law; (b) subsurface or latent physical conditions at the site differing from those indicated by information about the site made available to bidders prior to the deadline for submitting bids; (c) unknown physical conditions at the site of any unusual nature, different materially from those ordinarily encountered and generally recognized as inherent in work of the character provided for in the Contract Documents.

Upon notice to Owner, Owner shall promptly investigate the conditions, and if it finds that the conditions do materially so differ, or do involve hazardous waste, and cause a decrease or increase in the Contractor's cost of, or the time required for, performance of any part of the work shall issue a change order under the procedures described in the Agreement.

In the event that a dispute arises between Owner and Contractor whether the conditions materially differ, or involve hazardous waste, or cause a decrease or increase in Contractor's cost of, or time required for, performance of any part of the work, Contractor shall not be excused from any scheduled completion date provided for by the Agreement, but shall proceed with all work to be performed under the Agreement. Contractor shall retain any and all rights provided either by Agreement or by law which pertain to the resolution of disputes and protests.

## **ARTICLE 9 – RECOURSE OF OWNER**

**9.1 NOTICE TO CURE.** If, in the opinion of Owner, Contractor is in breach of any provision of this Agreement, including but not limited to failing: to supply timely and enough properly skilled workers or proper or sufficient materials or equipment or adequate supervision; to provide and obtain approved submittals timely; to maintain the Schedule of Work; to make prompt payment to its workers, sub-subcontractors, suppliers, taxing authorities, or union trust funds; to obey laws, ordinances, or orders of any public authority having jurisdiction; to clean up its debris; to perform work as directed by Owner; or to perform any obligation under this Agreement, Contractor shall commence and continue satisfactory correction of such breach with diligence and promptness within forty-eight (48) hours after service of written notice to Contractor or Contractor's authorized representative specifying the particulars of such breach.

**9.2 FAILURE TO CURE BREACH.** If Contractor fails to cure a breach of this Agreement within forty-eight (48) hours of service of a Notice to Cure, Owner may, without prejudice to any other rights or remedies, and at its sole option, do any or all of the following:

(a) Furnish such labor, material, equipment, and other facilities, either directly or through one or more subcontractors, as Owner deems necessary to complete or correct Contractor's work, or any part thereof;

(b) Withhold payment of any monies due Contractor under this Agreement pending corrective action to the extent required by and to the satisfaction of Owner; or

(c) Terminate the Agreement and complete the work itself or cause the work to be completed by others. Owner may take immediate possession of all of Contractor's material, supplies, tools, appliances, and equipment at the job site and use same without payment of rent or other compensation to Contractor or liability to Contractor for any damages arising from said use unless resulting from gross negligence or willful destruction by Owner or others working on its behalf. Any unused material, supplies, tools, appliances, and equipment remaining after Contractor's work is completed will be returned to Contractor.

**9.3 CONTRACTOR RATES TO COMPLETE OR CORRECT WORK.** If Owner elects to use its own labor forces to complete or correct Contractor's work, Contractor and, if applicable, Contractor's surety, agree to pay Owner for all labor costs, costs for Owner's owned equipment, direct costs for materials, field and home office overhead, and ten percent (10%) profit on all costs.

**9.4 BANKRUPTCY.** Upon a receiver for Contractor being appointed, upon Contractor making an assignment for the benefit of creditors, upon Contractor seeking protection under the Bankruptcy Code, upon Contractor's creditors placing Contractor into an involuntary bankruptcy, or upon Contractor committing any other act evidencing insolvency, Owner may, to the extent legally permissible, terminate this Agreement upon giving three (3) working days' written notice, by certified mail, to Contractor and its surety, if any. If an order for relief pertaining to Contractor is entered under the Bankruptcy Code, Owner may terminate this Agreement by giving forty-eight (48) hours' written notice, by certified mail, to Contractor, its trustee, and its surety, if any, unless Contractor, the surety, or the trustee: promptly cures all defaults; provides adequate assurances of future performance; compensates Owner for all damages, costs, and expenses resulting from such default(s); and assumes the obligations of Contractor within the statutory time limits.

If Contractor is not performing in accordance with the Schedule of Work at the time an order for relief is entered, Owner may avail itself of any and all such remedies that are reasonably necessary to maintain the Schedule of Work while waiting for the Contractor, its trustee, or its surety, if any, to accept or reject the Agreement and to provide adequate assurances of future performance.

## **ARTICLE 10 – INSURANCE AND BONDS**

**10.1 GENERAL INSURANCE REQUIREMENTS.** Contractor shall not commence any work until it obtains all insurance required to be obtained by Contractor under this Agreement as set forth in the General Conditions and Attachment C hereto and incorporated herein by this reference.

**10.2 PERFORMANCE AND MATERIALS AND LABOR PAYMENT BONDS.** Within 5 calendar days of a request by Owner, and at Contractor’s expense, Contractor shall furnish Performance and Materials and Labor Payment Bonds in an amount equal to 100 percent of the Price set forth in Article 3 herein, from a surety and in a form satisfactory to and/or provided by Owner. Said bonds shall include a provision that the party prevailing in any legal or equitable action or arbitration proceeding relating to the bonds shall be entitled to receive from the other parties to said action or proceeding all court costs, actual attorneys’ fees, and all other expenses, including but not limited to expert witness fees, incurred in such action or proceedings and the preparation thereof.

## **ARTICLE 11 – INDEMNIFICATION**

**11.1 DEFINITIONS.** For purposes of this Article 11, “Indemnified Parties” shall mean: Owner, and all of their officials, representatives, employees, consultants, agents, successors, and assigns, and any lender of Owner with an interest in the Project.

For purposes of this Article 11, “Claim” and “Claims” shall include claims, demands, obligations, damages, actions, causes of action, suits, demands for arbitration, losses, judgments, fines, penalties, liabilities, costs, and expenses (including, without limitation, fees, costs, and other disbursements to attorneys, experts, consultants, or other professionals) of every kind or nature whatsoever that may arise from or in any manner relate (directly or indirectly) to any work performed or services provided under this Agreement or Contractor’s presence or activities conducted at the Project.

**11.2 EXTENT OF INDEMNIFICATION.** To the fullest extent permitted by law, Contractor

shall indemnify and hold harmless the Indemnified Parties, and each of them, from and against any and all Claims including, without limitation, Claims for bodily injury, death, or damage to or destruction of property; defects in workmanship or materials; and design defects, if the design originated with Contractor, that may arise from or in any manner relate, directly or indirectly, to any work performed or services provided under this Agreement or Contractor's presence or activities conducted on the Project, including without limitation the negligent and/or willful acts, errors, and/or omissions of Contractor, its principals, officers, agents, employees, vendors, suppliers, consultants, sub-consultants, sub-subcontractors, anyone employed by any of them or for whose acts they may be liable, or any or all of them, regardless of any passive negligence or strict liability of an Indemnified Party. Contractor, however, shall not be obligated under this Agreement to indemnify, including the cost to defend, the Indemnified Parties for Claims arising out of, pertaining to, or relating to the active negligence or willful misconduct of the Indemnified Parties, or for defects in design furnished by such persons, or to the extent the Claims do not arise out of the scope of work of the Contractor pursuant to this Agreement.

**11.3 DUTY TO DEFEND.** Contractor shall, at its sole cost and expense and with legal counsel approved by Owner (which approval shall not be unreasonably withheld), defend the Indemnified Parties, and each of them, from any Claims for which Contractor is bound to indemnify the Indemnified Parties pursuant to Article 11.2. The duty to defend is wholly independent of and separate from the duty to indemnify, and such duty to defend exists regardless of any ultimate liability of Contractor. Such defense obligation shall arise immediately upon presentation of a Claim and written notice of such Claim being provided to Contractor.

**11.4 PAYMENT NOT CONDITION PRECEDENT.** Payment to Contractor by any Indemnified Party, or any Indemnified Party's payment of a Claim, shall not be a condition precedent to Contractor's obligations to indemnify and defend the Indemnified Parties, and each of them.

**11.5 SURVIVAL OF OBLIGATION.** Contractor's obligations to indemnify and defend shall survive the expiration or earlier termination of this Contract Agreement until such time as any action against the Indemnified Parties, or any of them, for such matter indemnified hereunder is fully and finally barred by the applicable statute(s) of limitations.

**11.6 LIABILITY NOT EXCLUSIVE.** Contractor's liability for indemnification and defense hereunder is in addition to any liability Contractor may have to Owner for Contractor's breach of any of the provisions of this Agreement. Under no circumstances shall the insurance requirements and limits set forth in this Agreement be construed to limit Contractor's indemnification obligation or other liability under the Agreement.

**11.7 NO LIMITATION UPON LIABILITY.** In connection with any and all claims against

Owner, Owner's representatives, Contractor (including its affiliates, parents, and subsidiaries) or other contractors or subcontractors, or any of their agents or employees, by any employee of Contractor, anyone directly or indirectly employed by Contractor, or anyone for whose acts Contractor may be liable, the indemnification provisions in Article 11.2 shall not be limited in any way by any limitation on the amount or types of damages, compensation or benefits payable by or on behalf of Contractor under worker's compensation acts, disability benefit acts, or other employee benefit acts.

## **ARTICLE 12 – CLAIMS**

**12.1 CLAIMS RELATING TO OWNER.** Contractor agrees to make all claims for which Owner may be liable in the manner provided in the Contract Documents. Notice of such claims shall be given by Contractor to Owner within one (1) week prior to Contractor commencing work under this Agreement or the event for which such claim is to be made, or within three (3) calendar days of Contractor's first knowledge of the event, whichever shall first occur. Contractor's failure to provide notice of a claim as required by this Article 12.1 shall constitute a waiver of the claim. Contractor shall be bound by the determination of the Owner or, in the event of a legal action or proceeding, or arbitration, by the outcome of same and shall be entitled only to its proportionate share of any net recovery.

**12.2 CLAIMS NOT RELATING TO OWNER.** Contractor shall give Owner written notice of all claims not included in Article 12.1, within the same time frames noted in Article 12.1. Should Contractor fail to provide notice within the time required, such claims shall be deemed waived.

**12.3 CONTRACTOR TO CONTINUE WORK.** Contractor shall carry on the Work and maintain satisfactory progress while any claim or claims brought pursuant to Article 12.1 or 12.2, or any other dispute(s), is/are being resolved, and Owner shall continue to make payments in accordance with the Agreement.

## **ARTICLE 13 – DISPUTE RESOLUTION**

**13.1 CONSENSUAL RESOLUTION EFFORTS.** Upon notification of a dispute, Owner and Contractor shall meet to informally resolve such dispute.

**13.2 DISPUTES BETWEEN OWNER AND SUBCONTRACTOR.** Any controversy or claim arising out of or related to this Agreement involving an amount less than \$6,250 (or the maximum limit of the court) must be heard in the Small Claims Division of the Superior Court in Humboldt County. If any question arises regarding or relating to Contractor's work or regarding

the rights and obligations of Owner and/or Contractor under the Contract Documents, then, as a condition precedent to litigation as described below, Owner and Contractor shall first mediate any dispute. With respect to claims and disputes between Owner and Contractor arising out of or relating to obligations under this Agreement, and which do not involve issues of fact or law the following shall apply: Each claim or dispute between the parties arising out of or relating to this Agreement shall be litigated in a California State Court of competent jurisdiction, or if jurisdiction over the action cannot be obtained in California State Court, in a Federal Court of competent jurisdiction situated in the State of California.

**13.3 CONSOLIDATED ARBITRATION PROCEEDINGS.** The claims and disputes of Owner, Contractor, and other subcontractors involving a common question of fact or law shall be heard by the same arbitrator(s) or court in a single proceeding.

**13.4 NO LIMITATION OF RIGHTS OR REMEDIES.** This Article shall not be deemed a limitation of any rights or remedies that Contractor may have under any federal or state mechanics lien, stop notice, or labor and material payment bond unless such rights have been expressly waived by Contractor.

#### **ARTICLE 14 – MISCELLANEOUS PROVISIONS**

**14.1 LAW AND EFFECT.** This Agreement shall be governed by the laws of the State of California.

**14.2 SEVERABILITY AND WAIVER.** The partial or complete invalidity of any one or more provisions of this Agreement shall not affect the validity or continuing force and effect of any other provision.

**14.3 ATTORNEYS' FEES.** In the event either party shall prevail in any legal or equitable action or arbitration proceeding to enforce any term(s) of this Agreement, such party shall be entitled to receive from the other party all court costs, actual attorneys' fees, and all other expenses, including but not limited to expert witness fees, incurred in such litigation and the preparation thereof.

**14.4 ENTIRE AGREEMENT.** This Agreement is solely for the benefit of the signatories hereto and represents the entire and integrated agreement between the parties hereto, and supersedes all prior proposals, bids, correspondence, negotiations, representations, or agreements, whether written or oral.

**14.5 TERMS.** The terms of this Agreement are contractual and the result of negotiations between the parties hereto. Accordingly, any rule of construction of contracts, including without limitation California Civil Code section 1654, that ambiguities are to be construed against the drafting party, shall not be employed in the interpretation of this Agreement.

**14.6 WRITTEN NOTICE.** Written notice shall be deemed to have been duly served if delivered in person to the individual or a member of the firm or entity or to Contractor's authorized representative, or if delivered at or sent by registered or certified mail to the last business address known to the party giving notice.

**14.7 RIGHTS AND REMEDIES.** Duties and obligations imposed by the Contract Documents, and rights and remedies available thereunder, shall be in addition to and not a limitation of duties, obligations, rights, and remedies otherwise imposed or available by applicable law.

**14.8 AUDIT.** Owner shall have the right to inspect the work, or any portion thereof, at any time, in accordance with this Agreement and the Contract Documents. Any right of the Owner to inspect or audit the books, accounting records, files and documents of Contractor in accordance with the Contract Documents is incorporated herein as though set forth in full.

Owner shall have the right to inspect, audit and copy at any time, upon reasonable notice, during normal business hours, Contractor's books, documents and accounting records, including but not limited to bid worksheets, bids, subcontractor bids, and proposals, estimates, cost accounting data, accounting records, payroll records, time sheets, cancelled checks, profit and loss statements, balance sheets, Project correspondence, including but not limited to all correspondence between Contractor and Contractor's sureties and subcontractors/vendors, Project files, scheduling information, and other records of the Contractor and all subcontractors directly or indirectly pertinent to the work, original as well as change and claimed extra work, to verify and evaluate the accuracy of cost and pricing data submitted with any change order, prospective or completed, or any claim for which additional compensation has been requested or notice of potential claim has been tendered. Contractor shall keep complete and accurate records concerning Contractor's work and the Project at its principal office for at least four (4) years after the work is completed and accepted. This provision shall be included in all of Contractor's subcontracts and purchase orders, and all of Contractor's subcontractors and suppliers, of any tier, shall be bound by this provision.

**14.9 ASSIGNMENT OF CARTWRIGHT ACT CLAIMS.** If applicable, Contractor offers and agrees to assign to Owner all rights, title, and interest in and to all causes of action it may have

under Section 4 of the Clayton Act (15 U.S.C. Sec. 15) or under the Cartwright Act (Chapter 2 (commencing with Section 16700) of Part 2 of Division 7 of the Business and Professions Code), arising from purchases of goods, services, or materials pursuant to the Agreement. This assignment shall be made and become effective at the time Owner tenders final payment to the Contractor, without further acknowledgment by the parties.

**CONTRACTORS ARE REQUIRED BY LAW TO BE LICENSED AND REGULATED BY THE CONTRACTORS STATE LICENSE BOARD WHICH HAS JURISDICTION TO INVESTIGATE COMPLAINTS AGAINST CONTRACTORS IF A COMPLAINT REGARDING A PATENT ACT OR OMISSION IS FILED WITHIN FOUR YEARS OF THE DATE OF THE ALLEGED VIOLATION. A COMPLAINT REGARDING A LATENT ACT OR OMISSION PERTAINING TO STRUCTURAL DEFECTS MUST BE FILED WITHIN TEN YEARS OF THE DATE OF THE ALLEGED VIOLATION. ANY QUESTIONS CONCERNING A CONTRACTOR MAY BE REFERRED TO THE REGISTRAR, CONTRACTORS STATE LICENSE BOARD, POST OFFICE BOX 26000, SACRAMENTO, CALIFORNIA 95826.**

IN WITNESS WHEREOF, the parties have executed this Agreement in duplicate as of the day and year first above written. This Agreement may be executed in counterparts, each of which shall be deemed to be an original, and copies of which transmitted via facsimile or pdf shall be deemed originals, and which together shall be deemed one and the same agreement. To the extent the signed version of this Agreement is digitally stored, electronic copies have the same force and effect as the original.

HUMBOLDT COMMUNITY SERVICES DISTRICT, a [CONTRACTOR]  
public entity

By: \_\_\_\_\_

Name of Signee:

\_\_\_\_\_

Title:

\_\_\_\_\_

By: \_\_\_\_\_

Name of Signee: \_\_\_\_\_

Title:

Contractor's License No. \_\_\_\_\_

Attest: \_\_\_\_\_

Robert Christensen, HCSO Board Secretary



## Attachment C

### INSURANCE REQUIREMENTS

**Minimum Scope and Limits of Insurance:** Contractor shall procure and maintain for the duration of the contract, *and for 5 years thereafter*, insurance against claims for injuries or death to persons or damages to property which may arise from or in connection with the performance of the work hereunder by the Contractor, his agents, representatives, employees, or subcontractors.

**Coverage** - Coverage shall be at least as broad as the following:

6. **General Liability - Commercial General Liability (CGL)** - Insurance Services Office (ISO) Commercial General Liability Coverage (Occurrence Form CG 00 01) including products and completed operations, property damage, bodily injury, personal and advertising injury with limit of at least five million dollars (\$5,000,000) per occurrence or the full per occurrence limits of the policies available, whichever is greater. If a general aggregate limit applies, either the general aggregate limit shall apply separately to this project/location (coverage as broad as the ISO CG 25 03, or ISO CG 25 04 endorsement provided to Humboldt Community Services District) or the general aggregate limit shall be twice the required occurrence limit.
7. **Automobile Liability** - Insurance Services Office (ISO) Business Auto Coverage (Form CA 00 01), covering Symbol 1 (any auto) with limit of one million dollars (\$1,000,000) for bodily injury and property damage each accident.
8. **Workers' Compensation Insurance** -. The Contractor shall provide workers' compensation coverage as required by the State of California, with Statutory Limits, and Employer's Liability Insurance with limit of no less than \$1,000,000 per accident for bodily injury or disease. **Waiver of Subrogation** (also known as Transfer of Rights of Recovery Against Others to Us): The Contractor hereby agrees to waive rights of subrogation to obtain endorsement necessary to affect this waiver of subrogation in favor of Humboldt Community Services District, its directors, officers, employees, and authorized volunteers, for losses paid under the terms of this coverage which arise from work performed by the Named Insured for Humboldt Community Services District; this provision applies regardless of whether or not Humboldt Community Services District has received a waiver of subrogation from the insurer.
9. **Builder's Risk** – (Course of Construction) if necessary- insurance utilizing an "All Risk" (Special Perils) coverage form with limits equal to the completed value of the project and no coinsurance penalty provision. See **Responsibility for Work (page 51)**.

**10. Contractor's Pollution Liability** – with limits no less than \$2,000,000 per occurrence or claim, and \$4,000,000 policy aggregate.

If the Contractor maintains broader coverage and or/higher limits than the minimums shown above, Humboldt Community Services District requires and shall be entitled to the broader coverage and/or higher limits maintained by the Contractor. Any available insurance proceeds in excess of the specified minimum of insurance and coverage shall be available to Humboldt Community Services District)

**Other Required Provisions** – The Commercial General Liability policy and Contractors Pollution (if necessary) are to contain, or be endorsed to contain, the following provisions:

2. **Additional Insured Status:** Humboldt Community Services District, its directors, officers, employees, and authorized volunteers are to be given insured status (at least as broad as ISO Form CG 20 10 11 85) or if not available, through the addition of **both** CG 20 10 10 01 and CG 20 37 10 01, with respect to liability arising out of work or operations performed by or on behalf of the Contractor including materials, parts, or equipment furnished in connection with such work or operations. General liability coverage can be provided in the form of an endorsement to the Contractor's insurance.
  
2. **Primary Coverage:** For any claims related to this project, the Contractor's insurance coverage shall be primary (at least as broad as ISO CG 20 01 04 13) with respect to Humboldt Community Services District, its directors, officers, employees, and authorized volunteers. Any insurance or self-insurance maintained by Humboldt Community Services District, its directors, officers, employees, and authorized volunteers shall be excess of the Contractor's insurance and shall not contribute with it.

**Notice of Cancellation:** Each insurance policy required above shall provide that coverage shall not be canceled, except with notice to Humboldt Community Services District.

**Acceptability of Insurers** - Insurance is to be placed with insurers having a current A.M. Best rating of no less than A: VII or equivalent or as otherwise approved by Humboldt Community Services District. The Contractor agrees and he/she will comply with such provisions before commencing work. All of the insurance shall be provided on policy forms and through companies satisfactory to Humboldt Community Services District. Humboldt Community Services District reserves the right

to obtain complete, certified copies of all required insurance policies, including the policy declarations page with endorsement number. Failure to continually satisfy the Insurance requirements is a material breach of contract.

**Responsibility for Work** - Until the completion and final acceptance by Humboldt Community Services District of all the work under and implied by this agreement, the work shall be under the Contractor's responsible care and charge. The Contractor shall rebuild, repair, restore and make good all injuries, damages, re-erections, and repairs occasioned or rendered necessary by causes of any nature whatsoever.

The Contractor shall provide and maintain **builder's risk** (course of construction) or an installation floater (for materials and equipment) covering all risks of direct physical loss, damage or destruction to the work in the amount specified in the General Conditions, to insure against such losses until final acceptance of the work by Humboldt Community Services District. Such insurance shall insure at least against the perils of fire and extended coverage, theft, vandalism and malicious mischief, and collapse. The Policy shall be endorsed with Humboldt Community Services District, its directors, officers, employees, and authorized volunteers named as loss payee, as their interest may appear. The making of progress payments to the Contractor shall not be construed as creating an insurable interest by or for Humboldt Community Services District or be construed as relieving the Contractor or his/her subcontractors of responsibility for loss from any direct physical loss, damage or destruction occurring prior to final acceptance of the work by Humboldt Community Services District.

**Deductibles and Self-Insured Retentions** - Insurance deductibles or self-insured retentions must be declared by the Contractor, and approved by Humboldt Community Services District. At the election of Humboldt Community Services District, the Contractor shall either cause the insurer to reduce or eliminate such self-insured retentions as respects Humboldt Community Services District, its directors, officers, employees, and authorized volunteers or the Contractor shall provide a financial guarantee satisfactory to the Humboldt Community Services District guaranteeing payment of losses and related investigations, claim administration, and defense expenses. The policy language shall provide, or be endorsed to provide, that the self-insured retention may be satisfied by either the named insured or Humboldt Community Services District.

**Verification of Coverage - Evidences of Insurance** Contractor shall furnish Humboldt Community Services District with copies of certificates and amendatory endorsements effecting coverage required by this contract. All certificates and endorsements are to be received and approved by Humboldt Community Services District before work commences. However, failure to obtain the

required documents prior to the work beginning shall not waive the Contractor's obligation to provide them. Humboldt Community Services District reserves the right to require complete, certified copies of all required insurance policies, including policy Declaration pages and Endorsement pages, required by these specifications, at any time. Failure to continually satisfy the Insurance requirements is a material breach of contract.

**Continuation of Coverage** - The Contractor shall, upon demand of Humboldt Community Services District deliver evidence of coverage showing continuation of coverage for at least (5) years after completion of the project. Contractor further waives all rights of subrogation under this agreement. When any of the required coverages expire during the term of this agreement, the Contractor shall deliver the renewal certificate(s) including the general liability additional insured endorsement and evidence of waiver of rights of subrogation against Humboldt Community Services District (if builder's risk insurance is applicable) to Humboldt Community Services District at least ten (10) days prior to the expiration date.

**Sub-Contractors** - In the event that the Contractor employs other Contractors (sub-contractors) as part of the work covered by this agreement, it shall be the Contractor's responsibility to require and confirm that each sub-contractor meets the minimum insurance requirements specified above (via as broad as ISO CG 20 38 04 13). The Contractor shall, upon demand of Humboldt Community Services District, deliver to Humboldt Community Services District copies such policy or policies of insurance and the receipts for payment of premiums thereon.

**NON-COLLUSION AFFIDAVIT TO BE EXECUTED BY EACH AWARDEE OF A PRINCIPAL CONTRACT**

STATE OF CALIFORNIA  
COUNTY OF HUMBOLDT

\_\_\_\_\_, being first duly sworn, deposes and

says: That he/she is \_\_\_\_\_, the party making the foregoing proposal or bid; that such proposal or bid is genuine and not collusive or sham; that said Bidder has not colluded, conspired, connived, or agreed, directly or indirectly, with any bidder or person, to put in a sham bid or to refrain from bidding, and has not, in any manner, directly or indirectly, sought by agreement of collusion, or communication or conference, with any person, to fix the bid price of affianced or of any other bidder, or to fix any overhead, profit or cost element of said bid price, or of that of any other bidder, or to secure any advantage against the owner or any person interested in the proposed Contract; and that all statements in said proposal or bid are true.

**Doctor's Office Lane Sewer Rehabilitation Project**

Signature of Bidder: \_\_\_\_\_

Business Address: \_\_\_\_\_  
\_\_\_\_\_

Place of Residence: \_\_\_\_\_  
\_\_\_\_\_

**This Page Left Intentionally Left Blank**

**NOTARY ACKNOWLEDGMENT**

**CALIFORNIA ALL-PURPOSE ACKNOWLEDGMENT**

CIVIL CODE § 1189

A notary public or other officer completing this certificate verifies only the identity of the individual who signed the document to which this certificate is attached, and not the truthfulness, accuracy, or validity of that document.

State of California }  
County of Humboldt }

On \_\_\_\_\_ before me, \_\_\_\_\_  
*Date Here Insert name and Title of the Officer*

personally appeared \_\_\_\_\_  
*Name(s) of Signer(s)*

who proved to me on the basis of satisfactory evidence to be the person(s) whose name(s) is/are subscribed to the within instrument and acknowledged to me that he/she/they executed the same in his/her/their authorized capacity(ies), and that by his/her/their signature(s) on the instrument the person(s), or the entity upon behalf of which the person(s) acted, executed the instrument.

I certify under PENALTY OF PERJURY under the laws of the State of California that the foregoing paragraph is true and correct.

WITNESS my hand and official seal

\_\_\_\_\_  
Signature of Notary Public (Seal)

Place Notary Seal Above

**-----OPTIONAL-----**

Though this section is optional, completing this information can deter alteration of the document of fraudulent reattachment of this form to an unintended document.

**Description of Attached Document**

Title or Type of Document \_\_\_\_\_ Document Date: \_\_\_\_\_

Number of Pages \_\_\_\_\_ Signer(s) Other Than Named Above: \_\_\_\_\_

**Capacity(ies) Claimed by Signer(s)**

Signer's Name: \_\_\_\_\_  
 Corporate Officer—Title(s): \_\_\_\_\_  
 Partner —  Limited  General  
 Individual  Attorney in Fact  
 Trustee  Guardian or Conservator  
 Other: \_\_\_\_\_  
Signer is Representing: \_\_\_\_\_

Signer's Name: \_\_\_\_\_  
 Corporate Officer—Title(s): \_\_\_\_\_  
 Partner —  Limited  General  
 Individual  Attorney in Fact  
 Trustee  Guardian or Conservator  
 Other: \_\_\_\_\_  
Signer is Representing: \_\_\_\_\_

**This Page Left Intentionally Left Blank**



**PERFORMANCE BOND–100%**

KNOW ALL PERSONS BY THESE PRESENTS:

WHEREAS, The Humboldt Community Services District, County of Humboldt, State of California, by motion passed

\_\_\_\_\_, 20 , has awarded to \_\_\_\_\_

hereinafter designated as the "Principal," a contract for construction of **the Doctor's Office Lane Sewer Rehabilitation Project.**

WHEREAS, said Principal is required under the terms of said contract to furnish a bond for the faithful performance of said contract;

NOW THEREFORE, we, \_\_\_\_\_ as Principal, and, \_\_\_\_\_ as Surety, are held and firmly bound unto the Humboldt Community Services District, hereinafter called the "Owner," to the penal sum of \_\_\_\_\_ Dollars (\$ \_\_\_\_\_) lawful money of the United States of America, for which sum well and duly to be made, we bind ourselves, our heirs, executors, administrators, and successors, jointly and severally, firmly by these presents.

THE CONDITION OF THIS OBLIGATION IS SUCH that if the hereby bounden Principal, its heirs, executors, administrators, successors, or assigns shall in all things stand to and abide by and well and truly keep and perform all the undertakings, terms, covenants, conditions, and agreements in the said contract and any alteration thereof, made as therein provided, all within the time and in the manner therein designated and in all respects according to their true intent and meaning, then this obligation shall become null and void; otherwise, it shall be and remain in full force and virtue.

FURTHER, THE SAID SURETY, FOR VALUE RECEIVED, HEREBY STIPULATES AND AGREES that no change, extension of time, alteration, or modification of the Contract Documents or of the work to be performed thereunder, shall in any way affect its obligations on this bond, and it does hereby waive notice of any such change, extension of time, alteration, or modification of the Contract Documents or of work to be performed thereunder.

IN WITNESS WHEREOF, three (3) identical counterparts of this instrument, each of which shall for all purposes be deemed an original thereof, have been duly executed by Principal and Surety herein named, on the \_\_\_\_\_ day of \_\_\_\_\_, affixed, and these presents duly signed by its undersigned representative pursuant to authority of its governing body.

\_\_\_\_\_  
Principal

\_\_\_\_\_  
By

\_\_\_\_\_  
Title

\_\_\_\_\_  
Surety

\_\_\_\_\_  
By

\_\_\_\_\_  
Address of Surety

**PAYMENT BOND—100%**

KNOW ALL PERSONS BY THESE PRESENTS:

WHEREAS, The Humboldt Community Services District, County of Humboldt, State of California, by motion passed

\_\_\_\_\_, 20\_\_\_\_, has awarded to \_\_\_\_\_

hereinafter designated as the "Principal," a contract for construction of **the Doctor's Office Lane Sewer Rehabilitation Project**.

WHEREAS, said Principal is required under the terms of said contract to furnish a bond for the faithful performance of said contract;

NOW THEREFORE, we, \_\_\_\_\_ as Principal, and, \_\_\_\_\_ as Surety, are held and firmly bound unto the Humboldt Community Services District, hereinafter called the "Owner," to the penal sum of \_\_\_\_\_ Dollars (\$\_\_\_\_\_) lawful money of the United States of America, for which sum well and duly to be made, we bind ourselves, our heirs, executors, administrators, and successors, jointly and severally, firmly by these presents.

THE CONDITION OF THIS OBLIGATION IS SUCH that if the hereby bounden Principal, its heirs, executors, administrators, successors, or assigns shall in all things stand to and abide by and well and truly keep and perform all the undertakings, terms, covenants, conditions, and agreements in the said contract and any alteration thereof, made as therein provided, all within the time and in the manner therein designated and in all respects according to their true intent and meaning, then this obligation shall become null and void; otherwise, it shall be and remain in full force and virtue.

FURTHER, THE SAID SURETY, FOR VALUE RECEIVED, HEREBY STIPULATES AND AGREES that no change, extension of time, alteration, or modification of the Contract Documents or of the work to be performed thereunder, shall in any way affect its obligations on this bond, and it does hereby waive notice of any such change, extension of time, alteration, or modification of the Contract Documents or of work to be performed thereunder.

IN WITNESS WHEREOF, three (3) identical counterparts of this instrument, each of which shall for all purposes be deemed an original thereof, have been duly executed by Principal and Surety herein named, on the \_\_\_\_\_ day of \_\_\_\_\_, affixed, and these presents duly signed by its undersigned representative pursuant to authority of its governing body.

\_\_\_\_\_  
Principal

\_\_\_\_\_  
By

\_\_\_\_\_  
Title

\_\_\_\_\_  
Surety

\_\_\_\_\_  
By

\_\_\_\_\_  
Address of Surety

**CONTRACTOR'S/SUBCONTRACTOR'S CERTIFICATION CONCERNING STATE LABOR STANDARDS  
AND PREVAILING WAGES**

Project:

All contractors and subcontractors shall give the following certification to the District and forward certification to the District within 10 days after execution of any contract or subcontract.

- A. "I have read and understand the following statements:"
  - No contractor or subcontractor may be listed on a bid proposal for a public works project (submitted on or after March 1, 2015) unless registered with the Department of Industrial Relations pursuant to Labor Code section 1725.5 [with limited exceptions from this requirement for bid purposes only under Labor Code section 1771.1(a)].
  - No contractor or subcontractor may be awarded a contract for public works project (awarded on or after April 1, 2015) unless registered with the Department of Industrial Relations pursuant to Labor Code section 1725.5
  - This project is subject to compliance monitoring and enforcement by the Department of Industrial Relations.
  
- B. "I am aware of the provisions of Section 3700 of the Labor Code which require every employer to be insured against liability for workers' compensation or to undertake self insurance in accordance with the provisions of that code, and I will comply with such provisions before commencing the performance of the work of this contract."
  
- C. "I have received and am aware of Labor Code Sections 1720 through 1813 regarding California Prevailing Wage Laws."

---

Contractor/Subcontractor

---

(Signature) (Date)

---

Typed/Printed Name and Title

**This Page Left Intentionally Left Blank**

# Technical Specifications

**This Page Left Intentionally Left Blank**



## TECHNICAL SPECIFICATIONS

### Section 01 22 00 Measurement and Payment

#### **PART 1 GENERAL**

##### **1.1 GENERAL**

- A. Unless otherwise specified in other individual sections of these Specifications, quantities of work shall be determined from measurements or dimensions in horizontal planes.
- B. Units of measurement shall be in accordance with U.S. Standard Measures.
- C. Materials and unit price items of work are to be paid for on a measurement basis in accordance with Part 2 of this section.
- D. All work shall comply with the permitting requirements provided the HCSD Annual Encroachment Permit.
- E. Contractor shall provide the District with a minimum 30 days' notice prior to the start of construction so that traffic control efforts can be coordinated.

##### **1.2 LUMP SUM PRICE BREAKDOWN**

- A. Immediately after award of the Contract and prior to approval of initial payment request, the Contractor shall submit a cost breakdown list (Schedule of Values) to the District Engineer for all lump sum bid items. This list shall consist of the major components of work that make up the lump sum bid items, and shall be used for determining progress pay estimates. The Contractor shall fill in the amounts for each component, prorating general costs (such as, setup, overhead, and profit) in each component. The total components of each lump sum bid item shall equal the total of that lump sum bid item. If the amount indicated in the Contract for any item on the list appears unbalanced, it may be revised as deemed necessary by the District Engineer, unless the Contractor can substantiate these costs.
- B. Only work items of value to the District shall be included in the list. An item for cleanup shall be listed in the breakdown, in the amount of at least one quarter of one percent (0.25%) of the total bid item. If cleanup proceeds as the job progresses, then partial payments of these amounts will be made accordingly.

##### **1.3 WORKPLAN SUBMITTAL**

- A. The Contractor is responsible for generating and submitting a "Maintaining Sewer Service Work Plan" for District review that will outline the contractors plan to complete new sewer

construction while maintaining sewer service. The work plan must be submitted to the District **at minimum 30 days before work begins** to allow the District to review and approve the submittal. The workplan should provide a detailed description of the materials and labor necessary to keep each residence within the project extents in service during the **entirety** of the project duration. **The workplan must be approved by the District before construction can begin.**

## **PART 2 MATERIALS**

### **2.01 GENERAL**

- A. All work shall be completed and placed in compliance with the Plans and Specifications, and as directed by the District Engineer.

### **2.02 MEASUREMENT AND PAYMENT ITEMS**

- A. Doctor's Office Lane Sewer Rehabilitation Bid items are defined and measured as follows:

**Bid Item 1 Mobilization/Demobilization:** Payment for Mobilization/Demobilization shall be on the basis of a fixed **Lump Sum** bid price, and shall be considered as full compensation for furnishing all labor, equipment, and materials necessary to establish and maintain a physical presence at the project site for the duration of the work, including, but not limited to, attendance at periodic project meetings, compliance with applicable project reporting, invoicing, and progress payment processes, mobilization, temporary fencing as required, costs associated with acquiring additional work and staging areas as necessary, preparation of submittals, and demobilization. Two-thirds (67%) of the bid amount for this item shall be paid to the Contractor in the first progress payment. Upon completion of Demobilization and complete project clean-up satisfactory to the District Engineer, one-third (33%) of the bid amount for this item shall be paid to the Contractor in the final progress payment.

**Bid Item 2 Traffic Control:** Payment for Traffic Control shall be on the basis of a fixed **Lump Sum** bid price, and shall be considered as full compensation for all materials, labor, equipment and incidentals to provide construction traffic control; establishing detours and one lane traffic with flagmen. Traffic control shall meet the current Manual on Uniform Traffic Control Devices (MUTCD) requirements and meet the requirements of the Annual Encroachment Permit with Humboldt County that this project can operate under.

**Bid Item 3 6" Sewer Main PVC Lining:** Payment for 6" Sewer Main PVC Lining shall be on the basis of a **Linear Feet** bid price, and shall be considered as full compensation for all materials, labor, equipment and incidentals for the installation of folded PVC lining within the existing 6-inch sewer main line. The work shall conform to the

specifications outlined in the contract documents and applicable standards for trenchless rehabilitation methods.

**Bid Item 4**      **6" Sewer Main Installation:** Payment for 6" Sewer Main Installation shall be on the basis of a **Linear Feet** bid price for the actual amount of pipe placed as measured on the pipe slope through the manholes and to the grades as shown on the Plans. Payment shall be considered as full compensation for all materials, labor, equipment and incidentals to install the sewer main line complete in place, including, but not limited to, initial asphalt cutting (where required), excavation, hauling and disposal and/or abandonment of excavated material and existing pipe, bedding, shoring, temporary bypass sewer pumping, installation of pipe and fittings, cover material, control of grade, control of water, backfilling and compaction, testing, restoration work including sidewalk, curb, asphalt and striping, and cleanup. This is a live sewer line and the CONTRACTOR shall provide sanitary facilities for the employees and roadway must be clean of any spoil materials at all times.

**Bid Item 5**      **4" PVC Sewer Lateral Installation:** Payment for 4" PVC Sewer Lateral Installation shall be on the basis of a **Linear Feet** bid price for the actual amount of pipe placed as measured on the pipe slope through the manholes and to the grades as shown on the Plans. Payment shall be considered as full compensation for all materials, labor, equipment and incidentals to install the sewer main line complete in place, including, but not limited to, initial asphalt cutting (where required), excavation, hauling and disposal and/or abandonment of excavated material and existing pipe, bedding, shoring, temporary bypass sewer pumping, installation of pipe and fittings, cover material, installation of sewer lateral cleanouts, including, but not limited to, pipe, trace wire and other components as per Plan Detail, control of grade, control of water, backfilling and compaction, testing, restoration work including sidewalk, curb, asphalt and striping, and cleanup. This is a live sewer line and the CONTRACTOR shall provide sanitary facilities for the employees and roadway must be clean of any spoil materials at all times.

**Bid Item 6**      **Manhole Installation:** Payment for Manhole Installation shall be on the basis of a **Per Each** bid price , and shall be considered as full compensation for all materials, labor and equipment necessary to furnish and install the manholes with frame and cover set to grade with concrete collar complete in place, including all required excavation, hauling and disposal of excavated material, old pipe, backfill, shoring, temporary bypass sewer pumping, control of grade, control of water, and connection of the trunk and service lines at the locations shown on the Plans.

#### **Additive Bid Item(s)**

**Bid Item 7**      **Additional Traffic Control:** Payment for Traffic Control **beyond the scope of the project timeline due to project delays out of the control of the District and the Contractor** and shall be on the basis of a fixed **Per Day** bid price, and shall be

considered as full compensation for all materials, labor, equipment and incidentals to provide construction traffic control and a specific traffic management plan approved by the District and submitted to the County of Humboldt; establishing detours and one lane traffic with flagmen. The traffic control plan shall meet the current Manual on Uniform Traffic Control Devices (MUTCD) requirements and meet the requirements of the Humboldt County Encroachment permit submitted to the District **a minimum of 4 weeks** before construction begins. Any additional traffic control plans required by the County of Humboldt shall be provided and submitted by the Contractor and cost will be covered under this item.

**Bid Item 8 Additional Sewer Main PVC Lining:** Payment for Sewer Main PVC Lining **beyond the approximate quantities provided in the Plans** shall be on the basis of a **Per Linear Foot** bid price for the actual amount of pipe placed as measured on the pipe slope through the manholes and to the grades as shown on the Plans and shall be considered as full compensation for all materials, labor, equipment and incidentals for the installation of folded PVC lining within the existing 6-inch sewer main line. The work shall conform to the specifications outlined in the contract documents and applicable standards for trenchless rehabilitation methods.

**Bid Item 9 Additional Sewer Main Installation:** Payment for Sewer Main Installation **beyond the approximate quantities provided in the Plans** shall be on the basis of a **Per Linear Foot** bid price for the actual amount of pipe placed as measured on the pipe slope through the manholes and to the grades as shown on the Plans. Payment shall be considered as full compensation for all materials, labor, equipment and incidentals to install the sewer main line complete in place, including, but not limited to, initial asphalt cutting (where required), excavation, hauling and disposal and/or abandonment of excavated material and existing pipe, existing manhole removal, bedding, shoring, temporary bypass sewer pumping, installation of pipe and fittings, cover material, control of grade, control of water, backfilling and compaction, testing, restoration work including sidewalk, curb, asphalt and striping, and cleanup. This is a live sewer line and the CONTRACTOR shall provide sanitary facilities for the employees and roadway must be clean of any spoil materials at all times.

**Bid Item 10 Additional Sewer Lateral Installation:** Payment for Sewer Lateral Installation **beyond the approximate quantities provided in the Plans** shall be on the basis of a **Per Linear Foot** bid price for the actual amount of pipe placed as measured on the pipe slope through the manholes and to the grades as shown on the Plans. Payment shall be considered as full compensation for all materials, labor, equipment and incidentals to install the sewer main line complete in place, including, but not limited to, initial asphalt cutting (where required), excavation, hauling and disposal and/or abandonment of excavated material and existing pipe, bedding, shoring, temporary bypass sewer pumping, installation of pipe and fittings, cover material, installation of sewer lateral cleanouts, including, but not limited to, pipe, trace wire and other components as per plan detail, control of grade, control of water, backfilling and compaction, testing, restoration work including sidewalk, curb, asphalt and striping,

and cleanup. This is a live sewer line and the CONTRACTOR shall provide sanitary facilities for the employees and roadway must be clean of any spoil materials at all times.

**Bid Item 11**     **Additional Earthwork:** Payment for Earthwork **beyond the approximate quantities provided in the Plans** and shall be on a **Per Cubic Yard** basis for materials, labor, equipment and incidentals for additional earthwork, including but not limited to, initial asphalt cutting (where required), excavation, hauling and disposal and/or abandonment of excavated material and existing pipes, bedding, shoring, control of grade, control of water, backfilling and compaction, testing, restoration work including sidewalk, curb, asphalt and striping, and cleanup. **The District is not responsible for additional costs associated with trench failures and/or cave-ins.**

**Bid Item 12**     **Additional Paving:** Payment for Paving **beyond the approximate quantities provided in the Plans** and shall be on a **Per Square Yard** basis for materials, labor, equipment and incidentals for additional asphalt paving, including but not limited to, initial asphalt cutting (where required), removal, hauling and disposal and/or abandonment of excavated asphalt paving, control of grade, placement and compaction, testing, restoration work including sidewalk, curb, asphalt and striping, and cleanup.

**\*\* END OF SECTION \*\***

**This Page Left Intentionally Blank**

# Appendices

**This Page Left Intentionally Blank**



**Appendix A:  
Attachment A, Construction  
Plan Sheets**

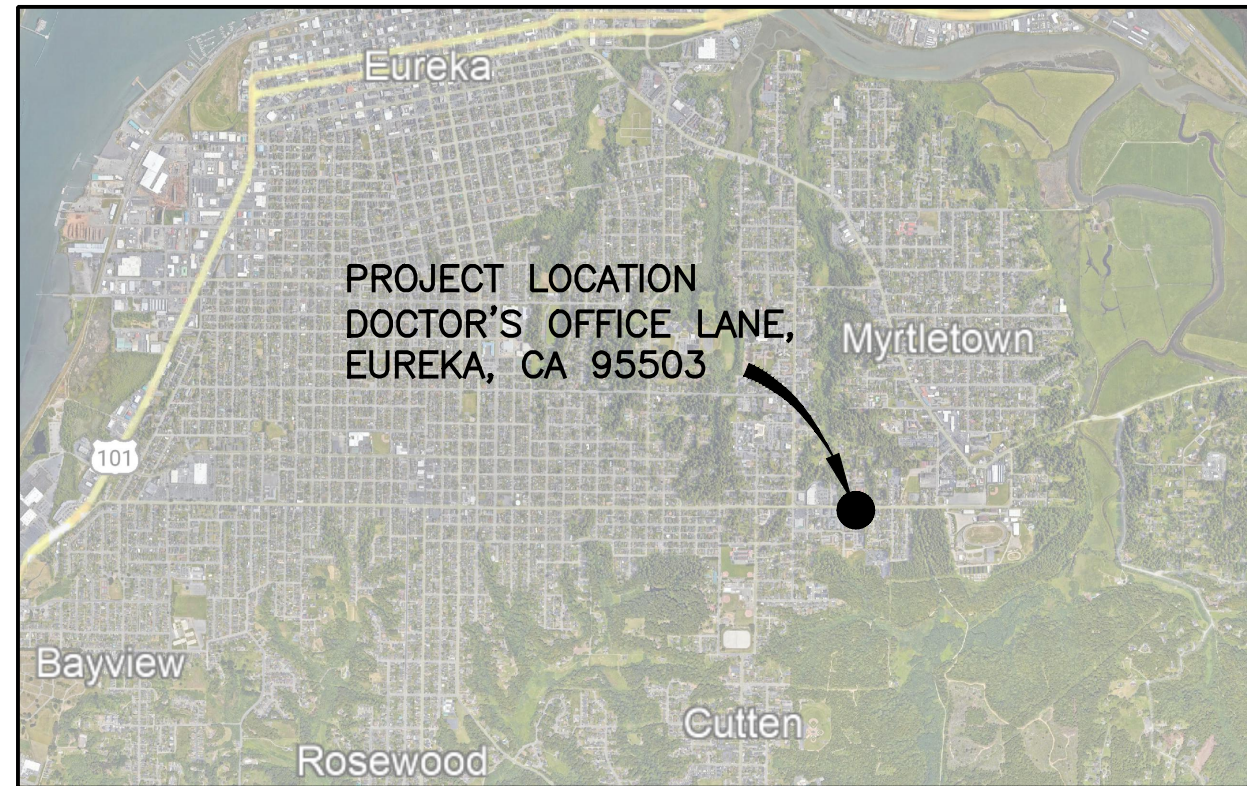

**LOCATION MAP**

NO SCALE

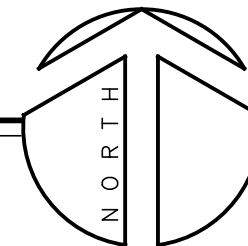

**PROJECT DATA**

**PROJECT DESCRIPTION**  
REPLACEMENT, LINING, AND UPGRADES OF EXISTING SANITARY SEWER ON DOCTOR'S OFFICE LANE (2800-2820 HARRIS STREET), AND ALONG HARRIS STREET BETWEEN ALORA LANE AND WALFORD AVENUE.

**PROJECT ADDRESS** - DOCTOR'S OFFICE LANE (2800-2820 HARRIS STREET), EUREKA, CA 95503

**APN** - 017-015-023

**CLIENT** - HUMBOLDT COMMUNITY SERVICES DISTRICT

**JURISDICTION** - COUNTY OF HUMBOLDT

**BUILDING CODES** - 2022 CBC, CPC, CEC, CFC

**SHEET INDEX**

1. VICINITY MAP & CONSTRUCTION NOTES
2. EXISTING SITE PLAN
3. PROPOSED SITE PLAN
4. PROFILES
5. STANDARD DETAILS
6. STANDARD DETAILS

**PROJECT INFORMATION:**

**CIVIL ENGINEER:**  
WHITCHURCH ENGINEERING INC.  
610 9TH STREET  
FORTUNA, CA 95540

**GENERAL NOTES**

1. ALL CONSTRUCTION, MATERIALS AND WORKMANSHIP SHALL CONFORM TO THE 2022 EDITION OF THE CALIFORNIA BUILDING CODE, 2022 EDITIONS OF THE CALIFORNIA ELECTRICAL AND FIRE CODES, AND ALL APPENDICES THERETO, CALTRANS STANDARD PLANS & SPECIFICATIONS, LATEST EDITION.
2. THE CONTRACTOR SHALL PROVIDE WORKMANS COMPENSATION INSURANCE & LIABILITY INSURANCE.
3. THE CONTRACTOR SHALL GUARANTEE ALL LABOR AND MATERIAL FOR A MINIMUM OF ONE YEAR.
4. THE GENERAL CONTRACTOR SHALL VERIFY ALL THE SITE CONDITIONS AND DIMENSIONS BEFORE STARTING WORK. THE CONTRACTOR SHALL NOTIFY THE OWNER'S REPRESENTATIVE OF ANY DISCREPANCIES.
5. FEATURES OF CONSTRUCTION SHOWN ARE TYPICAL AND SHALL APPLY GENERALLY THROUGHOUT SIMILAR CONDITIONS.
6. DETAILS SHOWN ON TYPICAL DETAIL SHEETS SHALL BE USED WHENEVER APPLICABLE, UNLESS OTHERWISE SHOWN. SPECIFIC DETAILS ON THE CIVIL DRAWINGS TAKE PRECEDENCE OVER TYPICAL DETAILS. SPECIFIC NOTES SHOWN ON THE CIVIL DRAWINGS TAKE PRECEDENCE OVER GENERAL NOTES. NOTES AND DETAILS ON THE STRUCTURAL DRAWINGS TAKE PRECEDENCE OVER SPECIFICATIONS.
7. ALL CONDITIONS SHOWN OR NOTED AS EXISTING ARE BASED ON BEST INFORMATION AVAILABLE AT THE TIME OF PREPARATION OF THESE DRAWINGS, NO WARRANTY IS IMPLIED AS TO THEIR ACCURACY.
8. ALL BUILDING MATERIAL SHALL BE NEW MATERIAL, UNLESS OTHERWISE APPROVED OR SPECIFIED BY ENGINEER.
9. CONTRACTORS SHALL VERIFY EASEMENTS (PUBLIC OR PRIVATE) FOR SEWER, WATER, ELECTRICAL, TELEPHONE, CABLE T.V., AND GAS PRIOR TO STARTING CONSTRUCTION.
10. VERIFY ALL UTILITY DATA AND LOCATIONS PRIOR TO ANY WORK. ONSITE UTILITIES SHALL BE COORDINATED WITH THE APPROPRIATE AGENCY OR UTILITY COMPANY.
11. THE DESIGN CONSULTANTS ASSUMES NO RESPONSIBILITY FOR THE PERFORMANCE OF PRODUCTS OR MATERIALS NOT SPECIFIED IN THESE DRAWINGS.
12. WRITTEN DIMENSIONS TAKE PRECEDENCE OVER SCALED DRAWINGS. WHERE DISCREPANCIES OCCUR NOTIFY THE OWNER'S REPRESENTATIVE FOR CLARIFICATION.
13. ACCEPT NO INK OR PENCIL CORRECTIONS TO THESE DRAWINGS WITHOUT THE OWNER'S REPRESENTATIVE INITIAL OR SIGNATURE. THE DESIGN CONSULTANTS SHALL BE HELD HARMLESS FOR ALL CHANGES NOT IN CONFORMANCE WITH THIS PROVISION.
14. ALL USERS OF THESE DRAWINGS AGREE BY USING THESE DRAWINGS TO HOLD THE DESIGN CONSULTANTS HARMLESS FOR ANY AND ALL WORK THAT DOES NOT CONFORM TO THE REQUIREMENTS AND MINIMUM STANDARDS OF THE C.B.C., ORDINANCES, AND ACCEPTABLE STANDARDS.
15. THESE DRAWINGS ARE THE PROPERTY OF THE DESIGN CONSULTANTS AND ARE NOT TO BE USED IN PART FOR ANY WORK OTHER THAN THE LOCATION SHOWN HEREON.
16. THE DESIGN CONSULTANTS AND THE OWNER SHALL HAVE NO CONTROL OR CHARGE OF AND SHALL NOT BE RESPONSIBLE FOR CONSTRUCTION MEANS, METHODS, TECHNIQUES, SEQUENCES OR PROCEDURES FOR ANY SAFETY PRECAUTIONS AND PROGRAMS IN CONNECTION WITH THE WORK.
17. THE CONTRACTOR SHALL COMPLY WITH ALL OF THE APPLICABLE REQUIREMENTS OF THE FEDERAL WILLIAMS - STEIGER OCCUPATIONAL SAFETY AND HEALTH ACT (OSHA) OF 1970' AND ANY AMENDMENTS THERETO. CONTRACTOR AGREES THAT HE SHALL ASSUME SOLE AND COMPLETE RESPONSIBILITY FOR JOB SITE CONDITIONS DURING THE COURSE OF CONSTRUCTION OF THIS PROJECT, INCLUDING SAFETY OF ALL PERSONS AND PROPERTY; THAT THIS REQUIREMENT SHALL APPLY CONTINUOUSLY AND NOT BE LIMITED TO NORMAL WORKING HOURS; AND THAT THE CONTRACTOR SHALL DEFEND, INDEMNIFY, AND HOLD THE OWNER AND THE ENGINEER HARMLESS FROM ANY AND ALL LIABILITY, REAL OR ALLEGED, IN CONNECTION WITH THE PERFORMANCE OF WORK ON THIS PROJECT, EXCEPTING FOR LIABILITY ARISING FROM THE SOLE NEGLIGENCE OF THE OWNER, THE ENGINEER OR HUMBOLDT COUNTY DEPARTMENT OF PUBLIC WORKS.
18. THE CONTRACTOR SHALL COMPARE ALL PAGES OF THE PLANS; ANY DISCREPANCIES SHALL BE REPORTED TO THE ENGINEER PRIOR TO PROCEEDING WITH WORK.
19. UPON COMPLETION OF THE PROJECT, THE CONTRACTOR AND SUBCONTRACTORS SHALL REMOVE SURPLUS MATERIALS AND DEBRIS FROM THE SITE. CONTRACTOR SHALL REMOVE ALL DELETERIOUS MATERIAL FROM SITE INCLUDING BUT NOT LIMITED TO; BROKEN CONCRETE, STUMPS, ROCKS, DEBRIS, ASPHALT RUBBLE, GARBAGE, ETC. AND LEGALLY DISPOSE OF ABOVE.
20. LOCATIONS AND ELEVATIONS OF EXISTING UNDERGROUND UTILITIES SHOWN HEREON ARE FROM RECORD INFORMATION ONLY AND ARE SHOWN FOR INFORMATION ONLY. THE CONTRACTOR SHALL BE RESPONSIBLE FOR LOCATING ALL UNDERGROUND UTILITIES PRIOR TO EXCAVATION AND CONSTRUCTION IN ANY AREA. CONTRACTOR SHALL CONTACT UNDERGROUND SERVICE ALERT (USA) AT 1-800-642-2444 A MINIMUM OF 48 HOURS IN ADVANCE OF ANY EXCAVATION. CONTRACTORS SHALL IMMEDIATELY REPORT ANY DISCREPANCIES IN RECORD INFORMATION TO ENGINEER AND DEVELOPER PRIOR TO CONSTRUCTING ANY WORK.
21. CONTRACTOR SHALL BE RESPONSIBLE FOR ALL SITE SAFETY REQUIREMENTS.
22. CONTRACTOR SHALL PROTECT ALL EXISTING IMPROVEMENTS ON OR ADJACENT TO PROJECT SITE. CONTRACTOR SHALL REPAIR OR REPLACE ALL DAMAGE TO EXISTING IMPROVEMENTS TO THE SATISFACTION OF HUMBOLDT COUNTY PUBLIC WORKS OR PRIVATE PROPERTY OWNER INVOLVED.
23. THE ENGINEER OF RECORD SHALL PROVIDE A FINAL LETTER OF CERTIFICATION TO THE HUMBOLDT COUNTY BUILDING DEPARTMENT CONFIRMING THE PROJECT HAS BEEN COMPLETED IN CONFORMANCE WITH THE APPROVED SOILS REPORT, GRADING, EROSION AND SEDIMENT CONTROL PLAN, AND STORM WATER POLLUTION PREVENTION PLAN.
24. CONTRACTOR SHALL SUBMIT A SHORING PLAN TO THE ENGINEER PRIOR TO CONSTRUCTION FOR APPROVAL.

**SITE PREPARATION**

1. ALL TOPSOIL, VEGETATION, ORGANICS, AND DEBRIS SHOULD BE REMOVED FROM THE PROPOSED BUILDING AND PAVEMENT AREAS. THE GENERAL DEPTH OF STRIPPING SHOULD BE SUFFICIENTLY DEEP TO REMOVE THE ROOT SYSTEMS AND ORGANIC TOP SOILS. FOR ESTIMATE PURPOSES, A MINIMUM STRIPPING DEPTH OF 6 INCHES SHOULD BE USED. THE ACTUAL DEPTH OF STRIPPING SHOULD BE REVIEWED BY THE SOILS CONSULTANT AT THE TIME OF CONSTRUCTION 0.5'-1.0' IS THE TYPICAL TOP SOIL DEPTH FOR THIS SITE. DEEPER STRIPPING MAY BE REQUIRED IN LOCALIZED AREAS. STRIPPING SHOULD EXTEND LATERALLY A MINIMUM OF 10 FEET OUTSIDE THE BUILDING AND PAVEMENT PERIMETERS. THESE MATERIALS WILL NOT BE SUITABLE FOR USE AS ENGINEERED FILL; HOWEVER, STRIPPED TOPSOIL MAY BE STOCKPILED AND REUSED IN LANDSCAPE AREAS AT THE DISCRETION OF THE OWNER.
2. THE CONTRACTOR SHOULD LOCATE ALL FOUNDATIONS, FLOOR SLABS, DEBRIS PITS, FILL SOILS, PAVEMENTS, AND SUBSURFACE STRUCTURES. THESE SOILS OR STRUCTURES SHOULD BE ENTIRELY REMOVED. THE RESULTING EXCAVATIONS SHOULD BE CLEANED OF ALL LOOSE OR ORGANIC MATERIAL, THE EXPOSED NATIVE SOILS SHOULD BE SCARIFIED TO A DEPTH OF 8 INCHES, THEN COMPACTED AS ENGINEERED FILL AND THE EXCAVATION BACKFILLED WITH ENGINEERED FILL.
3. ALL UTILITY LINES SHOULD BE LOCATED. THOSE UTILITY LINES NOT ANTICIPATED TO BE USED AFTER CONSTRUCTION SHOULD BE EXCAVATED AND REMOVED. UTILITY LINES SHOULD NOT BE CRUSHED AND LEFT IN PLACE. THE RESULTING EXCAVATIONS SHOULD BE CLEANED OF ALL LOOSE OR ORGANIC MATERIAL, THE EXPOSED NATIVE SOILS SHOULD BE SCARIFIED TO A DEPTH OF 6 INCHES, THEN COMPACTED AS ENGINEERED FILL AND THE EXCAVATION BACKFILLED WITH ENGINEERED FILL.
4. THE IN-PLACE DENSITY OF EXISTING UTILITY TRENCH BACKFILLS WHICH ARE ANTICIPATED TO REMAIN SHOULD BE DETERMINED. EXISTING TRENCH BACKFILL WITH A RELATIVE DENSITY LESS THAN 90 PERCENT PER ASTM D1557 SHOULD BE OVER-EXCAVATED AND REPLACED AS ENGINEERED FILL WITH A MINIMUM RELATIVE DENSITY OF 92 PERCENT.
5. THE CONTRACTOR SHOULD LOCATE ALL MONITORING AND/OR ON-SITE WATER WELLS. ALL WELLS SCHEDULED FOR DEMOLITION SHOULD BE ABANDONED PER STATE AND LOCAL REQUIREMENTS. ANY WELL (WATER OR MONITORING) THAT FALLS WITHIN THE BUILDING SHOULD BE ABANDONED. THE CONTRACTOR SHOULD OBTAIN AN ABANDONMENT PERMIT FROM THE LOCAL ENVIRONMENTAL HEALTH DEPARTMENT, AND ISSUE CERTIFICATES OF DESTRUCTION TO THE OWNER AND THE SOILS CONSULTANT UPON COMPLETION.
6. EXCAVATIONS BELOW GROUNDWATER CAN BE BACKFILLED USING EITHER A SAND-CEMENT SLURRY, OR GRAVEL ENCASED IN A GEOTEXTILE FILTER FABRIC OR ENGINEERED FILL MATERIAL. ONCE THE EXCAVATION IS BACKFILLED ABOVE THE GROUNDWATER TABLE, SILTY SAND SOILS SHOULD BE USED AS BACKFILL.
7. THE EXPOSED GROUND SURFACE IN AREAS TO RECEIVE ENGINEERED FILL MATERIAL, FLOOR SLABS OR PAVEMENTS SHOULD BE SCARIFIED TO A DEPTH OF 8 INCHES, MOISTURE CONDITIONED TO WITHIN TWO PERCENT OF OPTIMUM MOISTURE CONTENT AND COMPACTED AS ENGINEERED FILL. THE ZONE OF SCARIFICATION AND COMPACTION SHOULD EXTEND LATERALLY A MINIMUM OF 10 FEET OUTSIDE THE PERIMETERS OF THE BUILDINGS. THE SCARIFICATION AND COMPACTION SHALL BE CONDUCTED FOLLOWING STRIPPING OPERATIONS. REMOVAL OF SUBSURFACE STRUCTURES, OVER-EXCAVATION, AND REMOVAL OF ALL SOFT OR PLIANT AREAS.
8. ALL FILL REQUIRED TO BRING THE SITE TO FINAL GRADE SHOULD BE PLACED AS ENGINEERED FILL. IN ADDITION, ALL NATIVE SOILS OVER-EXCAVATED SHOULD BE COMPACTED AS ENGINEERED FILL.
9. IT SHOULD BE NOTED THAT WATER COULD SEEP INTO EXCAVATIONS. DEWATERING MAY BE REQUIRED. GROUNDWATER WILL ALSO IMPACT THE EXCAVATION, PLACEMENT, AND BACKFILL OF UTILITY LINES. CONTRACTORS SHOULD ANTICIPATE REMOVING WATER SEEPAGE. GRANULAR MATERIALS ENCASED IN A GEOTEXTILE STABILIZATION FABRIC, OR CEMENT-SAND SLURRY BACKFILL MATERIALS SHOULD BE ANTICIPATED WHEN BACKFILLING UTILITY LINES.
10. SUITABLE EXCESS CUT MATERIALS MAY BE RESUSED ON SITE TO FILL THE LID AREA AND THE NORTH SLOPE. MATERIAL SHALL BE PLACED AND COMPACTED PER THE SOILS REPORT.

**DUST CONTROL DURING CONSTRUCTION. DURING CONSTRUCTION ACTIVITIES,**

THE FOLLOWING DUST CONTROL MEASURES SHALL BE TAKEN:

1. WATER ALL ACTIVE CONSTRUCTION AREAS TWICE PER DAY AND USE EROSION CONTROL MEASURES TO PREVENT WATER RUNOFF CONTAINING SILT AND DEBRIS FROM ENTERING THE STORM DRAINAGE SYSTEM.
2. COVER TRUCKS HAULING SOIL, SAND AND OTHER LOOSE MATERIAL.
3. PAVE, WATER OR APPLY NON-TOXIC SOIL STABILIZERS ON UNPAVED ACCESS ROADS AND PARKING AREAS.
4. SWEEP PAVED ACCESS ROADS AND PARKING AREAS DAILY.
5. SWEEP STREETS DAILY IF VISIBLE MATERIAL IS CARRIED ONTO ADJACENT PUBLIC STREETS.
6. INSTALL EROSION CONTROL MEASURES TO PREVENT SILT RUNOFF TO PUBLIC ROADWAYS.
7. REPLANT VEGETATION IN DISTURBED AREAS WITHIN 30 DAYS OF COMPLETION OF PROJECT. THE RECONSTRUCTION SITE SHALL BE MAINTAINED IN A CLEAN AND ORDERLY FASHION AND BE KEPT FREE OF DEBRIS. SOLID WASTE GENERATE DURING CONSTRUCTION SHALL BE DISPOSED OF IN AN APPROPRIATE MANNER. SUCH WASTE SHALL INCLUDE, BUT NOT BE LIMITED TO: CONCRETE FORMS, WASTE CONCRETE AND ASPHALT, EMPTY CONTAINERS OF BUILDING MATERIALS AND EXCESS BUILDING MATERIALS.

**DISCOVERY OF PREHISTORIC OR ARCHAEOLOGICAL RESOURCES**

SHOULD CONCENTRATIONS OF ARCHAEOLOGICAL MATERIALS BE ENCOUNTERED DURING CONSTRUCTION OR GRADING OPERATIONS, ALL GROUND-DISTURBING WORK SHALL BE TEMPORARILY HALTED ON THE SITE. WORK NEAR THE ARCHAEOLOGICAL FINDS SHALL NOT BE RESUMED UNTIL A QUALIFIED ARCHAEOLOGIST HAS EVALUATED THE MATERIALS AND OFFERED RECOMMENDATIONS FOR FURTHER ACTION. PREHISTORIC MATERIALS WHICH COULD BE ENCOUNTERED INCLUDE: OBSIDIAN OR CHERT FLAKES OR TOOLS, LOCALLY DARKENED MIDDEN, GROUNDSTONE ARTIFACTS, DEPOSITIONS OF SHELL, DIETARY BONE, AND HUMAN BURIALS. SHOULD HUMAN REMAINS BE UNCOVERED, STATE LAW REQUIRES THAT THE COUNTY CORONER BE CONTACTED IMMEDIATELY. SHOULD THE CORONER DETERMINE THAT THE REMAINS ARE LIKELY THOSE OF A NATIVE AMERICAN, THE CALIFORNIA NATIVE AMERICAN HERITAGE COMMISSION MUST BE CONTACTED. THE HERITAGE COMMISSION CONSULTS WITH THE MOST LIKELY NATIVE AMERICAN DESCENDANTS TO DETERMINE THE APPROPRIATE TREATMENT OF THE REMAINS.

**DAYS AND HOURS OF CONSTRUCTION AND NOISE CONTROL.**

HOURS OF CONSTRUCTION AND NOISE CONTROL. THE FOLLOWING SHALL APPLY TO CONSTRUCTION NOISE FROM TOOLS AND EQUIPMENT:

1. THE OPERATION OF TOOLS OR EQUIPMENT USED IN CONSTRUCTION, DRILLING, REPAIR, ALTERATION OR DEMOLITION SHALL BE LIMITED TO BETWEEN THE HOURS OF 7 A.M. AND 5 P.M. MONDAY THROUGH FRIDAY. WEEKEND OPERATION MAY ONLY BE ACCEPTABLE, PROVIDED THAT THE COUNTY OF HUMBOLDT IS NOTIFIED 48 HOURS (2 BUSINESS DAYS) IN ADVANCE AND AGREES TO THE WEEKEND OPERATION.
2. NO HEAVY EQUIPMENT RELATED CONSTRUCTION ACTIVITIES SHALL BE ALLOWED ON SUNDAYS OR HOLIDAYS.
3. CONTRACTOR SHALL SELECT STAGING AREAS AS FAR AS FEASIBLY POSSIBLE FROM SENSITIVE RECEPTORS.
4. CONTRACTOR SHALL MAINTAIN ALL CONSTRUCTION EQUIPMENT WITH MANUFACTURER'S SPECIFIED NOISE-MUFFLING DEVICES.
5. UNNECESSARY IDLING OF INTERNAL COMBUSTION ENGINES SHALL BE PROHIBITED. THIS WOULD MEAN TURNING OFF EQUIPMENT IF IT WILL NOT BE USED FOR 5 OR MORE MINUTES.
6. ALL STATIONARY NOISE-GENERATING CONSTRUCTION EQUIPMENT SUCH AS AIR COMPRESSORS AS FAR AS POSSIBLE FROM HOMES AND BUSINESSES.
7. CONTRACTOR SHALL SELECT QUIET CONSTRUCTION EQUIPMENT, PRIMARY AIR COMPRESSORS, WHENEVER POSSIBLE.
8. TRUCK DRIVERS SHALL ADHERE TO POSTED SPEED ON LOCAL ROADS. ALTERNATE TRUCK ROUTES SHALL BE CONSIDERED IF COMPLAINTS OCCUR.

**SPECIFICATIONS:**

PIPES:

A. SANITARY SEWER PIPE SHALL BE CONSTRUCTED:

1. PIPE SECTIONS TO BE REPLACED SHALL BE POLYVINYL CHLORIDE (PVC) CONFORMING TO ASTM F667 WITH SDR 35 OR BETTER EQUIVALENT.
2. ALL LINES TO HAVE #10 COATED COPPER TRACER WIRE INSTALLED PER HCSD STANDARDS.
3. ALL LINES THAT REQUIRED COUPLINGS SHALL BE FITTED WITH CALDER STYLE SHIELDED SEWER COUPLINGS PER HCSD STANDARDS.
4. PIPE SECTIONS TO BE LINED SHALL BE FOLDED PVC OR APPROVED EQUIVALENT, CONFORMING TO ASTM F1504 WITH SDR 35 OR BETTER EQUIVALENT AND SHALL BE INSTALLED PER ASTM F1947.

B. ASPHALT PAVING SHALL BE CONSTRUCTED OF

1. 3/4" HOT MIX ASPHALT, TYPE B, CONFORMING TO CALTRANS STANDARD SPECIFICATION SECTION 39.
2. THE FINISHED SURFACE OF THE ASPHALT CONCRETE SHALL BE WITHIN 0.05 FOOT OF THE DESIGN GRADES.

C. CLASS 2 AGGREGATE BASE SHALL BE CONSTRUCTED OF:

1. 1 1/2 INCH MAXIMUM AS DEFINED IN SECTION 26-1.02B OF THE CALTRANS STANDARD SPECIFICATIONS (2018 EDITION)
2. WHERE SPECIFIED AGGREGATE BASE THICKNESS IS 0.50 FOOT OR LESS, THE AGGREGATE BASE MAY BE SPREAD AND COMPACTED IN ONE LAYER.
3. WHERE SPECIFIED AGGREGATE BASE THICKNESS IS GREATER THAN 0.50 FOOT, SPREAD AND COMPACT IN 2 OR MORE LAYERS APPROXIMATELY EQUAL IN THICKNESS. THE COMPACTED THICKNESS OF ANY ONE LAYER MUST NOT EXCEED 0.50 FOOT.
4. ALL AGGREGATE BASE SHALL BE COMPACTED TO 95% RELATIVE COMPACTION.

D. SAND SHALL BE SAND EQUIVALENT 45.

E. RIVER RUN GRAVELS MAY BE USED FOR SUB BASE MATERIALS FOR THE ROADWAY. A COMPACTION OF 90% OR BETTER PER ASTM D-1557 IS REQUIRED.

**ENCROACHMENT NOTES:**

HUMBOLDT COUNTY SERVICES DISTRICT HOLDS THE ENCROACHMENT PERMIT NO. 2513. THE FOLLOWING NOTES ARE WRITTEN WITH RESPECT TO THE SPECIFIC REQUIREMENTS LISTED IN THE PERMIT

1. ANY OPENING OR EXCAVATION MATE UNDER THE AUTHORITY OF THIS PERMIT SHALL NOT EXCEED FOUR (4) FEET IN WIDTH AND/OR FIFTY (50) FEET IN LENGTH.
2. THE MINIMUM OVERHEAD CLEARANCE OF CABLES AT ALL ROAD CROSSINGS SHALL BE EIGHTEEN FEET (18').
3. NO COMPLETE ROAD CLOSURE IS AUTHORIZED UNDER THIS PERMIT, UNLESS AUTHORIZED IN WRITING BY THE DIRECTOR OF PUBLIC WORKS.
4. EXCAVATIONS SHALL BE CONDUCTED IN SUCH A MANNER THAT NOT MORE THAN ONE TRAFFIC LANE IS CLOSED AT ANY ONE TIME.
5. NO OPEN TRENCHES WITHIN COUNTY RIGHT OF WAY SHALL BE ALLOWED DURING NON-WORKING HOURS.
6. BACKFILL MATERIAL USED IN ALL TRENCHES SHALL CONFORM TO SECTION 19 OF CALTRANS STANDARD SPECIFICATIONS, DATE 2018. THE ATTACHED TYPE 1 TRENCH DETAIL SHALL BE USED FOR ALL ROADS.
7. ALL TRENCHES SHALL BE TEMPORARILY CAPPED WITH A MINIMUM OF THREE INCHES (3") OF COLD MIX PRIOR TO OPENING THE ROADWAY TO PUBLIC TRAFFIC.
8. PERMANENT PAVEMENT RESTORATION SHALL CONSISTS OF MINIMUM OF THREE (3") INCHES OF TYPE B ASPHALT CONCRETE (HOT MIX).
9. THE DEPARTMENT OF PUBLIC WORKS RESERVES THE RIGHT TO MAKE AS MANY COMPACTION TESTS AS IT DEEMS REASONABLY NECESSARY TO ENSURE THAT THE COMPACTION REQUIREMENTS ARE MET.
10. THE OPERATION OF TOOLS OR EQUIPMENT USED IN CONSTRUCTION, DRILLING, REPAIR, ALTERATION OR DEMOLITION SHALL BE LIMITED TO BETWEEN THE HOURS OF 7 A.M. AND 5 P.M. MONDAY THROUGH FRIDAY. WEEKEND OPERATION MAY ONLY BE ACCEPTABLE, PROVIDED THAT THE COUNTY OF HUMBOLDT IS NOTIFIED 48 HOURS (2 BUSINESS DAYS) IN ADVANCE AND AGREES TO THE WEEKEND OPERATION.

**SUBMITTALS:**

THE FOLLOWING DOCUMENTATION IS TO BE SUBMITTED TO THE ENGINEER PRIOR TO CONSTRUCTION:

1. SHORING PLAN
2. PRODUCT SPECIFICATIONS
3. ASPHALT CONCRETE MIX DESIGN

THESE PLANS ARE ORIGINALLY PRINTED ON 22"x34" PAPER.

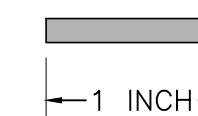

REVISIONS	BY
△ PLN_CHK 8-22-24	ALW
△ BID_PCKG 1-31-25	FMT



**WHITCHURCH ENGINEERING, INC.**  
 610 9th Street Fortuna, California 95540  
 Phone (707) 444-1420

**DOCTOR'S OFFICE LANE SEWER REHAB DESIGN**  
 PROJECT ADDRESS: DR. OFFICE LN.  
 (2800-2820 HARRIS ST), EUREKA, CA 95503  
 APN: 017-015-023  
**VICINITY MAP & CONSTRUCTION NOTES**  
 For: HUMBOLDT COMMUNITY SERVICES DISTRICT, G.M. TERRENCE WILLIAMS  
Drawn: Terrence Williams 2/25/2022, Checked: G.M. Williams 2/25/2022, Date: 2/25/2022

Date	JUL 17, 24'
Scale	AS NOTED
Design	ALW
Drawn	ALW
Job	HCD 2302.2
Sheet	1

This drawing or drawing set shall not be used for construction unless a jurisdictional stamp (County, City, State, Federal) has been issued on the drawing, stating "FOR PERMIT" or similar verbiage, a wet signed professional engineer's stamp, and permit documents have been issued for the project.

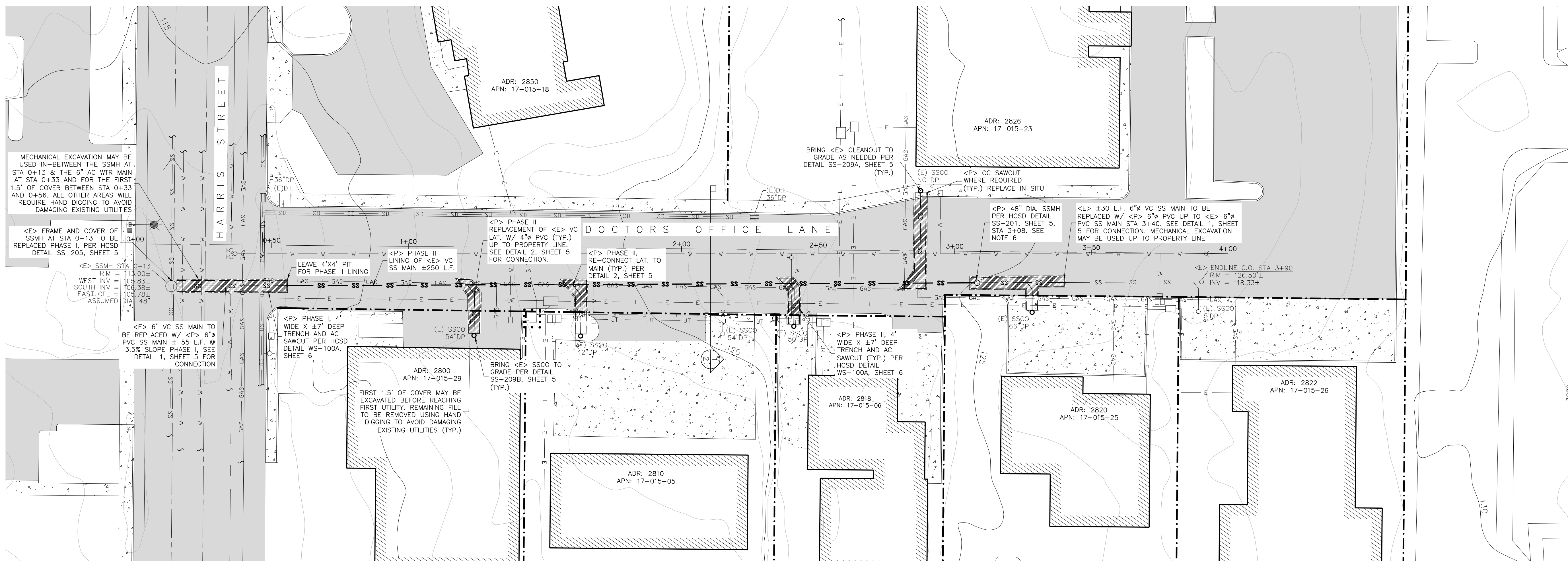

**ABBREVIATIONS**

AC	ASPHALT CONCRETE PAVING
AC	ASBESTOS CEMENT PIPE
ADR	ADDRESS
AGG.	AGGREGATE
APN	ASSESSOR'S PARCEL NUMBER
BW	BACK OF WALK
BO	BLOW-OFF
CATV	CABLE TELEVISION
CC	CONCRETE
CD	CENTERLINE
CO	CLEANOUT
COE	CITY OF EUREKA
CONC.	CONCRETE
DI	DRAINAGE INLET
DIP	DUCTILE IRON PIPE
DP	DROP
(E)	EAST
(E)	EXISTING
EL	ELEVATION
ELEC.	ELECTRICAL
EP	EDGE OF PAVEMENT
EV	ELECTRICAL VAULT
EXIST.	EXISTING
FL	FIRE HYDRANT
FL	FLOW LINE
FW	FRONT OF WALK
GD	GROUND
GM	GAS METER
GRD	GROUND
IP	IRON PIPE
JP	JOINT UTILITY POLE
JB	JUNCTION BOX
LAT	LATERAL
MH	MANHOLE
MIN.	MINIMUM
(N)	NORTH
<N>	NEW
P.P.	POWER POLE
P.P.	PROPOSED
P.S.I.	POUNDS PER SQUARE INCH
PUE	PUBLIC UTILITY EASEMENT
R/W	RIGHT OF WAY
SD	STORM DRAIN
S.F.	SQUARE FOOT
SHT.	SHEET
SS	SANITARY SEWER
SSCO	SANITARY SEWER CLEANOUT
SSMH	SANITARY SEWER MANHOLE
SD	STORM DRAIN
SO	SQUARE
(S)	SOUTH
STA	STATION
STD.	STANDARD
STL	STEEL
SWK.	SIDEWALK
T.B.M.	TEMPORARY BENCH MARK TO BE REPLACED
TBR	TO BE REPLACED
TC	TOP OF CURB
TOG	TOP OF GRATE
TYP.	TYPICAL
THK.	THICK
UTIL.	UTILITY
VC	VITRIFIED CLAY
W	WATER
WTR	WATER
W	WITH
(W)	WEST
WM	WATER METER
WV	WATER VALVE

**LEGEND**

	EXISTING AC PAVING
	EXISTING CONCRETE
	PROPOSED CONCRETE
	PROPOSED AC PAVING
	MAJOR CONTOUR
	MINOR CONTOUR
	ASSUMED RIGHT OF WAY/PROPERTY LINE
	EXISTING FOG LINE
	EXISTING CENTER LINE
	EXISTING WATER
	EXISTING GAS
	EXISTING JOINT TRENCH
	EXISTING ELECTRICAL
	EXISTING SEWER TO REMAIN
	EXISTING SEWER TO BE REPLACED
	EXISTING SEWER TO BE LINED
	EXISTING FIRE HYDRANT
	EXISTING SSCO
	EXISTING WATER VALVE
	EXISTING WATER METER
	EXIST SSCO
	PROPOSED SSMH

**SITE NOTES:**

- EXISTING UTILITIES, PROPERTY LINES, AND TOPOGRAPHY ARE BASED ON HUMBOLDT COMMUNITY SERVICES DISTRICT EXISTING LINE REHAB PROPOSAL PLANS DATED FEBRUARY 2023.
- LOCATION AND ELEVATION OF EXISTING UNDERGROUND UTILITIES BASED ON PROFILE FROM HUMBOLDT COMMUNITY SERVICES DISTRICT EXISTING LINE REHAB PROPOSAL PLANS DATED FEBRUARY 2023. CONTRACTOR TO VERIFY PRIOR TO CONSTRUCTION.
- ALL NEW SANITARY SEWER LINE TO BE CAMERA SCOPED AND DEPTH MEASUREMENTS ARE TO BE RECORDED BEFORE ACCEPTING INTO SERVICE.
- ALL NEW SANITARY SEWER LATERAL LINES TO BE 4" DIA. SDR 35 PVC UNLESS OTHERWISE STATED.
- NEW MANHOLE TO INCLUDE RUN OUT IN CHANNEL TO ALLOW FOR SEWER CAMERA ACCESS.
- SANITARY SEWER MANHOLE PROPOSED AT 3+08 IN ORDER TO NOT EXCEED THE MAXIMUM DISTANCE BETWEEN MANHOLES OF 300 FT. SET BY THE CPC STANDARD 719.6.
- HSCD STAFF SHALL BE PRESENT TO SEE THE CONNECTIONS MADE TO THE EXISTING INFRASTRUCTURE AT THE EDGE OF ROW PRIOR TO BACKFILL.
- MAINTAIN EXISTING SEPARATIONS OR BETTER BETWEEN UTILITIES IN ACCORDANCE WITH STANDARD DETAILS.

**LINER NOTES:**

- PIPE SECTIONS TO BE LINED SHALL BE FOLDED PVC OR APPROVED EQUIVALENT, CONFORMING TO ASTM F1504 WITH SDR 35 OR BETTER EQUIVALENT AND SHALL BE INSTALLED PER ASTM F1947 AND MANUFACTURER INSTRUCTIONS.
- THE PHYSICAL PROPERTIES OF THE INSTALLED LINER SHALL BE VERIFIED THROUGH FIELD SAMPLING AND LABORATORY TESTING. ALL MATERIALS FOR TESTING SHALL BE FURNISHED BY THE CONTRACTOR. ALL MATERIALS TESTING SHALL BE PERFORMED AT THE OWNER'S EXPENSE, BY AN INDEPENDENT THIRD PARTY LABORATORY APPROVED BY THE OWNER. ALL TESTS SHALL BE IN ACCORDANCE WITH APPLICABLE ASTM TEST METHODS.
- THE CONTRACTOR SHALL PROVIDE SAMPLES FOR TESTING TO THE OWNER FROM THE ACTUAL INSTALLED LINER. SAMPLES SHALL BE PROVIDED, AT A MINIMUM FROM ONE (1) LOCATION PER 1,000 LINEAR FEET OF LINER INSTALLED OR AS REQUIRED BY THE OWNER. THE SAMPLE SHALL BE CUT FROM A SECTION OF CURED LINER THAT HAS BEEN INVERTED OR PULLED THROUGH A LIKE DIAMETER PIPE THAT HAS BEEN HELD IN PLACE BY A SUITABLE HEAT SINK, SUCH AS SANDBAGS. ALL CURING, CUTTING, AND IDENTIFICATION OF SAMPLES WILL BE WITNESSED BY THE OWNER OR OWNERS REPRESENTATIVE AND TRANSMITTED BY THE OWNER OR OWNERS REPRESENTATIVE TO THE TESTING LABORATORY THE OPENING PRODUCED FROM THE SAMPLE SHALL BE REPAIRED IN ACCORDANCE WITH MANUFACTURERS RECOMMENDED PROCEDURES.
- THE LABORATORY RESULTS SHALL IDENTIFY THE TEST SAMPLE LOCATION AS REFERENCED TO THE NEAREST MANHOLE AND STATION. IF PROPERTIES TESTED DO NOT MEET THE MINIMUM PHYSICAL AND THICKNESS REQUIREMENTS, THE LINER SHALL BE REPAIRED OR REPLACED BY THE CONTRACTOR.
- CHEMICAL RESISTANCE: THE LINER SYSTEM INSTALLED SHALL MEET THE CHEMICAL RESISTANCE REQUIREMENTS OF ASTM F1504 (OR APPROVED EQUIVALENT). A CERTIFICATION MAY BE SUBMITTED, BY THE CONTRACTOR, FROM THE MANUFACTURER, VERIFYING THAT THE CHEMICAL RESISTANCE OF THE LINER MEETS THE CONTRACT REQUIREMENTS.
- THE INSTALLED LINER THICKNESS SHALL BE MEASURED FOR EACH LINE SECTION INSTALLED. IF THE LINER THICKNESS DOES NOT MEET THAT SPECIFIED IN THE CONTRACT AND SUBMITTED AS THE APPROVED DESIGN BY THE CONTRACTOR, THEN THE LINER SHALL BE REPAIRED OR REMOVED.
- ALL COSTS, TO THE CONTRACTOR, ASSOCIATED WITH PROVIDING LINER SAMPLES TO THE OWNER OR OWNERS REPRESENTATIVE FOR TESTING SHALL BE INCLUDED IN THE UNIT PRICE BID FOR LENGTH OF LINER.

**PROPOSED SITE PLAN (AREA OF WORK)**

SCALE: 1"=20'

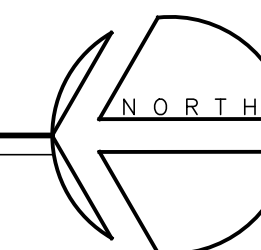

**PHASING NOTES:**

- PHASE I:**  
THE PURPOSE OF THIS CONSTRUCTION PHASE IS TRENCHING AND SHORING TO REMOVE AND REPLACE THE EXISTING SANITARY SEWER MAIN RUNNING FROM DOCTORS OFFICE LANE TO THE SANITARY SEWER MANHOLE ON HARRIS STREET (STATION 0+13 TO STATION 0+55). THIS PHASE ALSO INCLUDES THE REPLACEMENT OF THE FRAME AND COVER OF THE SANITARY SEWER MANHOLE AT STATION 0+13.
- PHASE II:**  
THE PURPOSE OF THIS CONSTRUCTION PHASE IS THE CLEANING AND LINING OF THE SANITARY SEWER MAIN IN DOCTORS OFFICE LANE, REMOVAL AND REPLACEMENT OF THE EXISTING SANITARY SEWER LATERALS WITHIN THE RIGHT OF WAY, BRINGING EXISTING SANITARY SEWER LATERAL CLEANOUTS TO GRADE, AND INSTALLING A NEW MANHOLE (STATION 3+08). THIS WORK WILL OCCUR FROM STATION 0+55 TO STATION 4+00.

THESE PLANS ARE ORIGINALLY PRINTED ON 22"x34" PAPER.

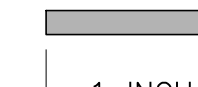

REVISIONS	BY
PLN_CHK 8-22-24	ALW
BID_PCKG 1-31-25	FMT



WHITCHURCH ENGINEERING, INC.  
610 9th Street Fortuna, California 95540  
Phone (707) 444-1420

DOCTOR'S OFFICE LANE SEWER REHAB DESIGN  
PROJECT ADDRESS: DR. OFFICE LN.  
(2800-2820 HARRIS ST), EUREKA, CA 95503  
APN: 017-015-023

PROPOSED SITE PLAN  
For: HUMBOLDT COMMUNITY SERVICES DISTRICT, G.M. TERRENCE WILLIAMS  
Sewer Rehab Design/WHITCHURCH 25022 REV. 1.31.25.dwg 2/17/2025

Date	JUL 17, 24'
Scale	AS NOTED
Design	ALW
Drawn	ALW
Job	HCD 2302.2
Sheet	3

This drawing or drawing set shall not be used for construction unless a jurisdictional stamp (County, City, State, Federal) has been issued on the drawing, stating "FOR PERMIT" or similar verbiage, a wet signed professional engineer's stamp, and permit documents have been issued for the project.

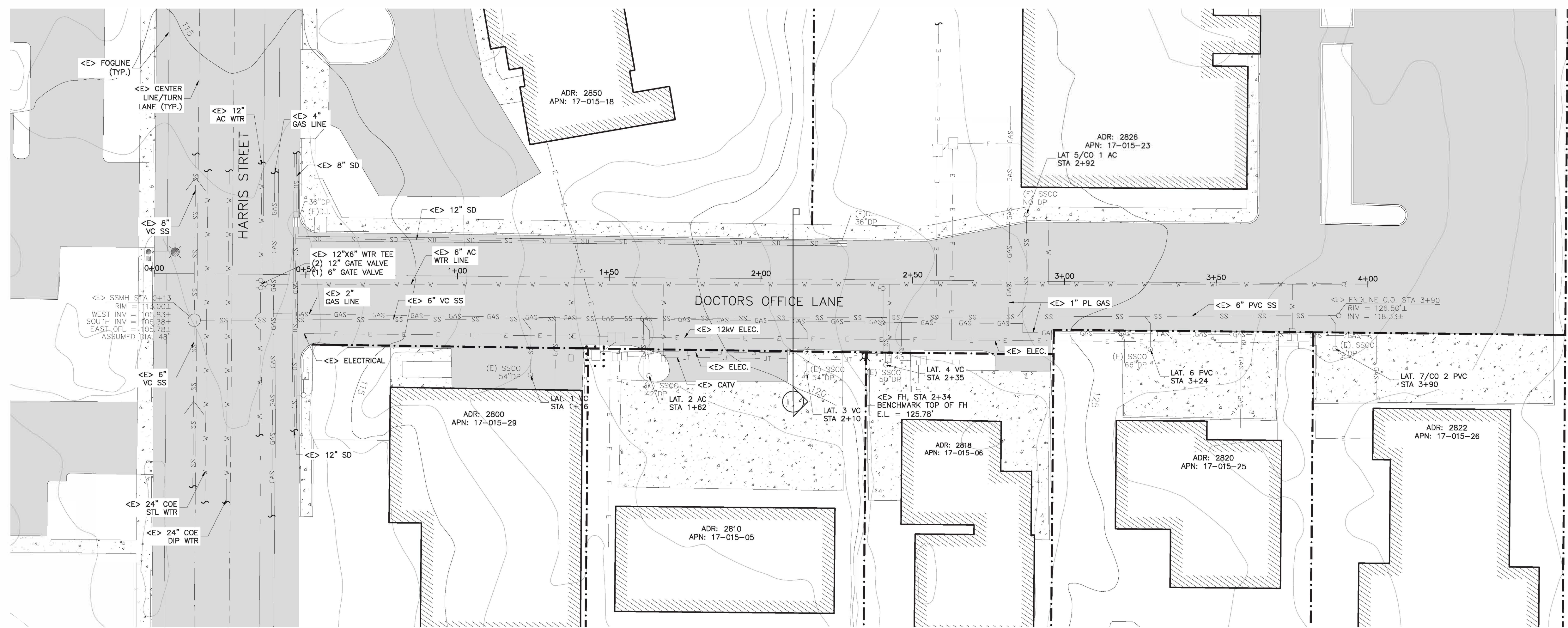

REVISIONS	BY
△ PLN CHK 8-22-24	ALW
△ BID PCKG 1-31-25	FMT



**WHITCHURCH ENGINEERING, INC.**  
 610 9th Street Fortuna, California 95540  
 Phone (707) 444-1420

**ABBREVIATIONS**

- AC ASPHALT CONCRETE PAVING
- ASB ASBESTOS CEMENT PIPE
- ADR ADDRESS
- AGG AGGREGATE
- APN ASSESSORS PARCEL NUMBER
- BW BACK OF WALK
- BO BLOW-OFF
- CATV CABLE TELEVISION
- CC CONCRETE
- CL CENTERLINE
- CO CLEANOUT
- COE CITY OF EUREKA
- CONC CONCRETE
- DI DRAINAGE INLET
- DIP DUCTILE IRON PIPE
- DP DROP
- (E) EAST
- (E) EXISTING
- ELEV ELEVATION
- ELEC ELECTRICAL
- EP EDGE OF PAVEMENT
- EV ELECTRICAL VAULT
- EXIST EXISTING
- FH FIRE HYDRANT
- FL FLOW LINE
- FW FRONT OF WALK
- GD GROUND
- GM GAS METER
- GRD GROUND
- IP IRON PIPE
- JP JOINT UTILITY POLE
- JB JUNCTION BOX
- LAT LATERAL
- MH MANHOLE
- MIN MINIMUM
- (N) NORTH
- (N) NEW
- P.P. POWER POLE
- P.P. PROPOSED
- P.S.I. POUNDS PER SQUARE INCH
- PUE PUBLIC UTILITY EASEMENT
- R/W RIGHT OF WAY
- SD STORM DRAIN
- S.F. SQUARE FOOT
- SHT. SHEET
- SS SANITARY SEWER
- SSCO SANITARY SEWER CLEANOUT
- SSMH SANITARY SEWER MANHOLE
- SD STORM DRAIN
- SO SQUARE
- (S) SOUTH
- TR TELEPHONE VAULT
- STA STATION
- STD. STANDARD
- STL STEEL
- SWK. SIDEWALK
- T.B.M. TEMPORARY BENCH MARK TO BE REPLACED
- TBR TO BE REPLACED
- TC TOP OF CURB
- TOG TOP OF GRADE
- TYP. TYPICAL
- THK. THICK
- UTIL. UTILITY
- VC VITRIFIED CLAY
- W WATER
- WTR WATER
- W WITH
- (W) WEST
- WM WATER METER
- WV WATER VALVE

**LEGEND**

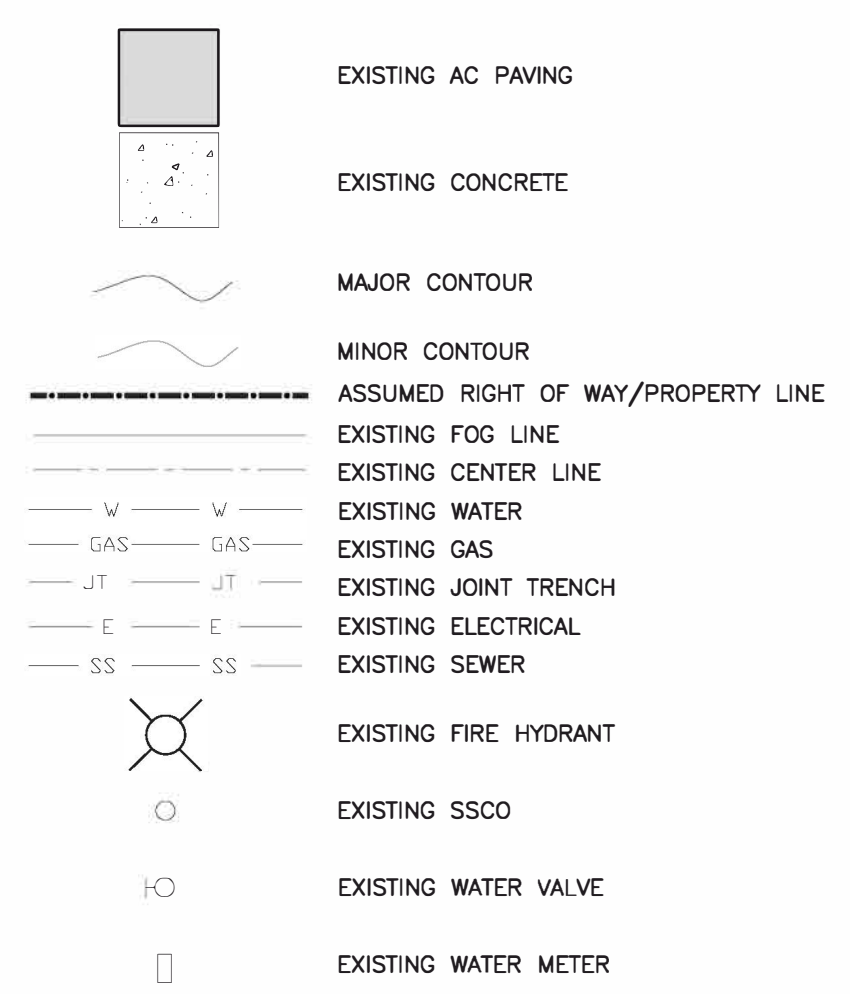

**NOTES:**

1. EXISTING UTILITIES, PROPERTY LINES, AND TOPOGRAPHY ARE BASED ON HUMBOLDT COMMUNITY SERVICES DISTRICT EXISTING LINE REHAB PROPOSAL PLANS DATED FEBRUARY 2023.
2. LOCATION AND ELEVATION OF EXISTING UNDERGROUND UTILITIES BASED ON PROFILE FROM HUMBOLDT COMMUNITY SERVICES DISTRICT EXISTING LINE REHAB PROPOSAL PLANS DATED FEBRUARY 2023. CONTRACTOR TO VERIFY PRIOR TO CONSTRUCTION.
3. ALL EXISTING SANITARY SEWER LATERALS ARE PRESUMED TO BE 4" DIA.

**EXISTING SITE PLAN (AREA OF WORK)**

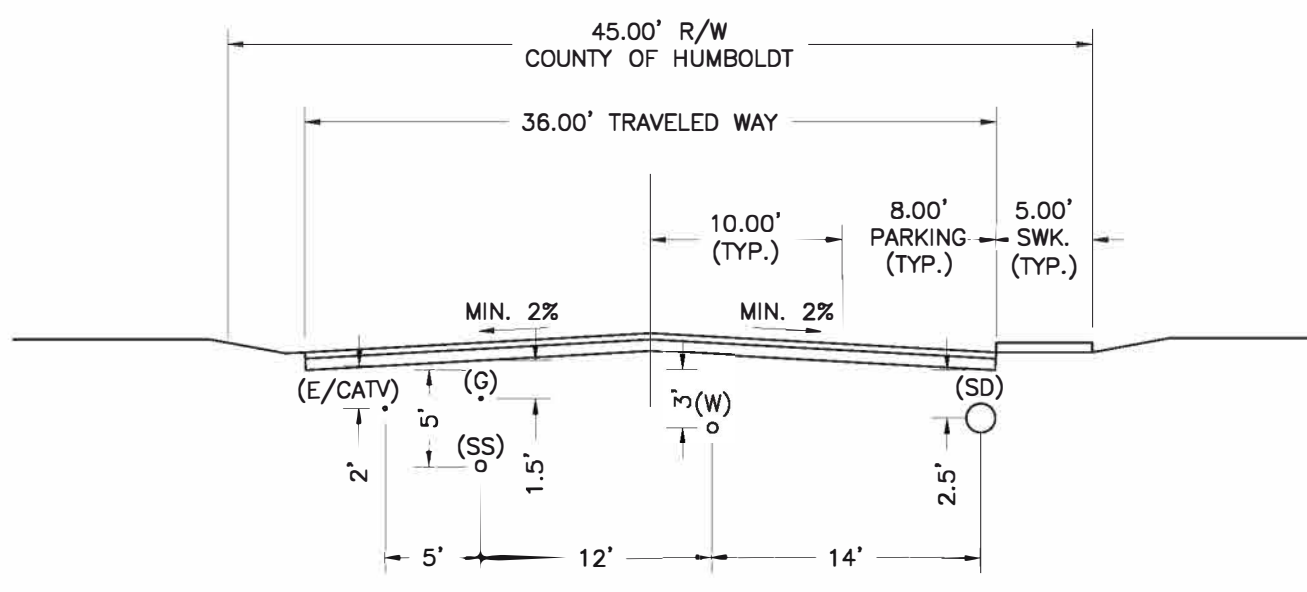

**1**  
**TYPICAL ROADWAY SECTION**  
 NO SCALE

THESE PLANS ARE ORIGINALLY  
 PRINTED ON 22"x34" PAPER.

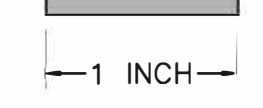

<p style="text-align: center;"><b>DOCTOR'S OFFICE LANE SEWER REHAB DESIGN</b></p> <p style="text-align: center;">PROJECT ADDRESS: DR. OFFICE LN.        (2800-2820 HARRIS ST), EUREKA, CA 95503</p> <p style="text-align: center;">APN: 017-015-023</p>	<p style="text-align: center;"><b>EXISTING SITE PLAN</b></p> <p style="text-align: center;">For: HUMBOLDT COMMUNITY SERVICES DISTRICT, G.M. TERRENCE WILLIAMS</p>
Date	JUL 17, 24'
Scale	AS NOTED
Design	ALW
Drawn	ALW
Job	HCD 2302.2
Sheet	2

This drawing or drawing set shall not be used for construction unless a jurisdictional stamp (County, City, State, Federal) has been issued on the drawing, stating "FOR PERMIT" or similar verbiage, a wet signed professional engineer's stamp, and permit documents have been issued for the project.

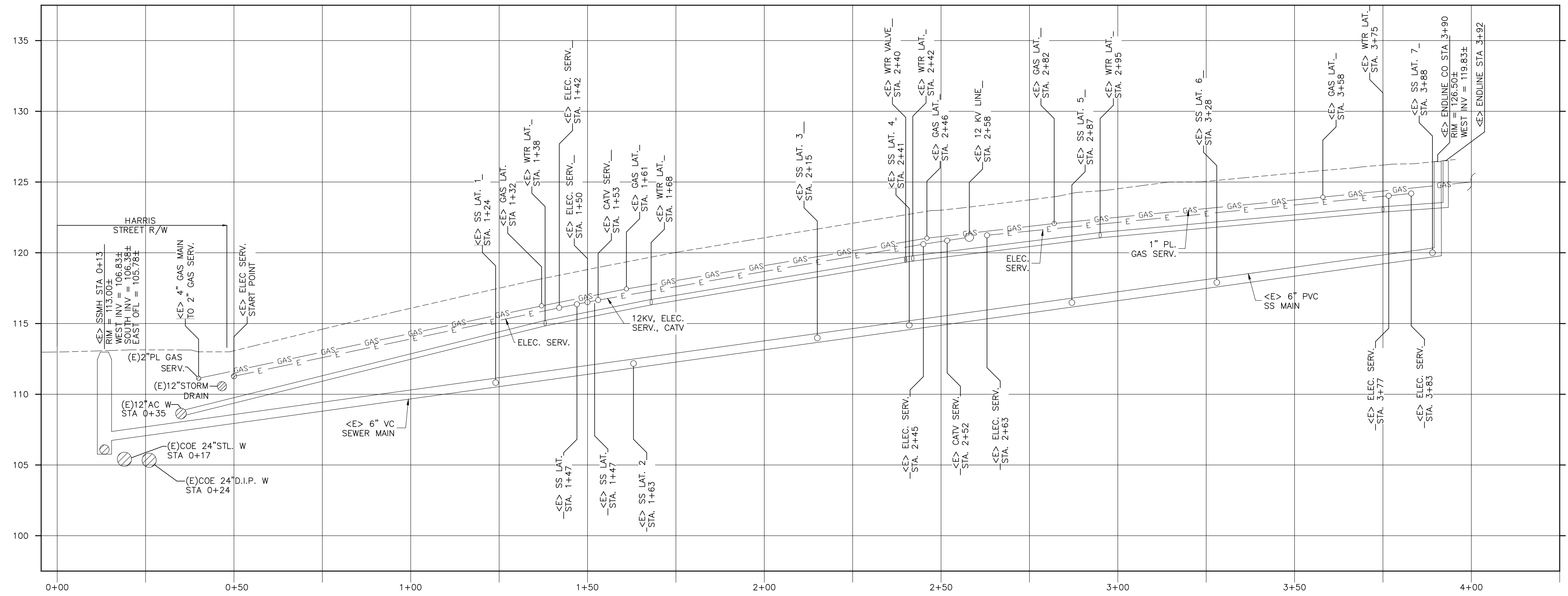

**EXISTING PROFILE STA. 0+00 TO STA. 4+00**

SCALE: 1"=20' HORIZ.  
1"=5' VERT.

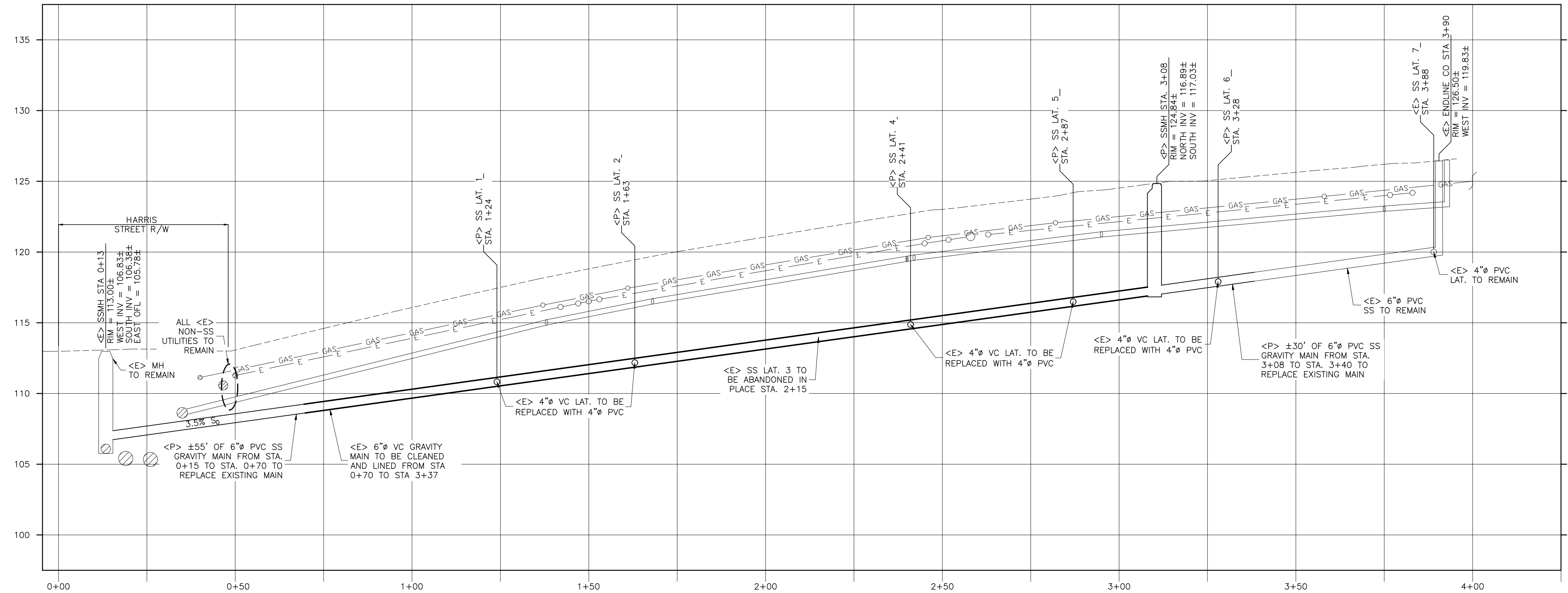
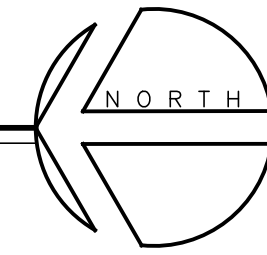

**PROPOSED PROFILE STA. 0+00 TO STA. 4+00**

SCALE: 1"=20' HORIZ.  
1"=5' VERT.

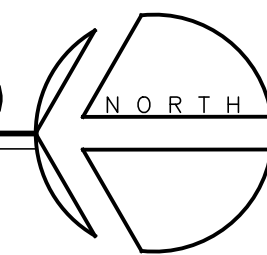

**ABBREVIATIONS**

- AC ASPHALT CONCRETE PAVING
- ADP ASBESTOS CEMENT PIPE
- AGG. AGGREGATE
- APN ASSESSORS PARCEL NUMBER
- BW BACK OF WALK
- BO BLOW-OFF
- CATV CABLE TELEVISION
- CC CONCRETE
- CL CENTERLINE
- CLEANOUT CLEANOUT
- COE CITY OF EUREKA
- CONC. CONCRETE
- DI DRAINAGE INLET
- DIP DUCTILE IRON PIPE
- DP DROP
- (E) EAST
- EXIST. EXISTING
- EL. ELEVATION
- EL. ELEC. ELECTRICAL
- EP EDGE OF PAVEMENT
- EV ELECTRICAL VAULT
- EXIST. EXISTING
- EX. EXISTING
- FL FLOW LINE
- FW FRONT OF WALK
- GD GROUND
- GM GAS METER
- GR GROUND
- IP IRON PIPE
- JUB JOINT UTILITY POLE
- JB JUNCTION BOX
- LAT LATERAL
- MH MANHOLE
- MIN. MINIMUM
- (N) NORTH
- (N) NEW
- P.P. POWER POLE
- PROPOSED PROPOSED
- P.S.I. POUNDS PER SQUARE INCH
- PUE PUBLIC UTILITY EASEMENT
- R/W RIGHT OF WAY
- SD STORM DRAIN
- S.F. SQUARE FOOT
- SHT. SHEET
- SS SANITARY SEWER
- SSCO SANITARY SEWER CLEANOUT
- SSMH SANITARY SEWER MANHOLE
- SD STORM DRAIN
- SQ SQUARE
- (S) SOUTH
- TR TELEPHONE VAULT
- STA STATION
- STD. STANDARD
- STEEL STEEL
- SWK SIDEWALK
- T.B.M. TEMPORARY BENCH MARK
- TBR TO BE REPLACED
- TC TOP OF CURB
- TOG TOP OF GRATE
- TYP. TYPICAL
- THK. THICK
- UTIL. UTILITY
- VC VITRIFIED CLAY
- W WATER
- WTR WATER
- W/ WITH
- WM WEST
- WM WATER METER
- WW WATER VALVE

**LEGEND**

- EXISTING GROUND SURFACE
- EXISTING WATER
- EXISTING GAS
- EXISTING JOINT TRENCH
- EXISTING ELECTRICAL
- EXISTING SEWER TO REMAIN
- EXISTING SEWER TO BE REPLACED
- EXISTING SEWER TO BE LINED

**SITE NOTES:**

1. EXISTING UTILITIES, PROPERTY LINES, AND TOPOGRAPHY ARE BASED ON HUMBOLDT COMMUNITY SERVICES DISTRICT EXISTING LINE REHAB PROPOSAL PLANS DATED FEBRUARY 2023.
2. LOCATION AND ELEVATION OF EXISTING UNDERGROUND UTILITIES BASED ON PROFILE FROM HUMBOLDT COMMUNITY SERVICES DISTRICT EXISTING LINE REHAB PROPOSAL PLANS DATED FEBRUARY 2023. CONTRACTOR TO VERIFY PRIOR TO CONSTRUCTION.
3. ALL NEW SANITARY SEWER LINE TO BE CAMERA SCOPED AND DEPTH MEASUREMENTS ARE TO BE RECORDED BEFORE ACCEPTING INTO SERVICE.
4. ALL NEW SANITARY SEWER LATERAL LINES TO BE 4" DIA. DR. 35 PVC UNLESS OTHERWISE STATED.
5. NEW MANHOLE TO INCLUDE RUN OUT IN CHANNEL TO ALLOW FOR SEWER CAMERA ACCESS.
6. SANITARY SEWER MANHOLE PROPOSED AT 3+08 IN ORDER TO NOT EXCEED THE MAXIMUM DISTANCE BETWEEN MANHOLES OF 300 F.T. SET BY THE CPC STANDARD 719.6.
7. HSCD STAFF SHALL BE PRESENT TO SEE THE CONNECTIONS MADE TO THE EXISTING INFRASTRUCTURE AT THE EDGE OF ROW PRIOR TO BACKFILL.
8. MAINTAIN EXISTING SEPARATIONS OR BETTER BETWEEN UTILITIES IN ACCORDANCE WITH STANDARD DETAILS.

THESE PLANS ARE ORIGINALLY PRINTED ON 22"x34" PAPER.



This drawing or drawing set shall not be used for construction unless a jurisdictional stamp (County, City, State, Federal) has been issued on the drawing, stating "FOR PERMIT" or similar verbiage, a wet signed professional engineer's stamp, and permit documents have been issued for the project.

REVISIONS	BY
△ PLN_CHK 8-22-24	ALW
△ BID_PCKG 1-31-25	FMT



2/4/2025  
Whitchurch Engineering, Inc.  
610 9th Street Fortuna, California 95540  
Phone (707) 444-1420

DOCTOR'S OFFICE LANE SEWER REHAB DESIGN  
PROJECT ADDRESS: DR. OFFICE LN.  
(2800-2820 HARRIS ST), EUREKA, CA 95503  
APN: 017-015-023  
FOR: HUMBOLDT COMMUNITY SERVICES DISTRICT, G.M. TERRENCE WILLIAMS  
PROFILE VIEWS

Date	JUL 17, 24'
Scale	AS NOTED
Design	ALW
Drawn	ALW
Job	HCD 2302.2
Sheet	4

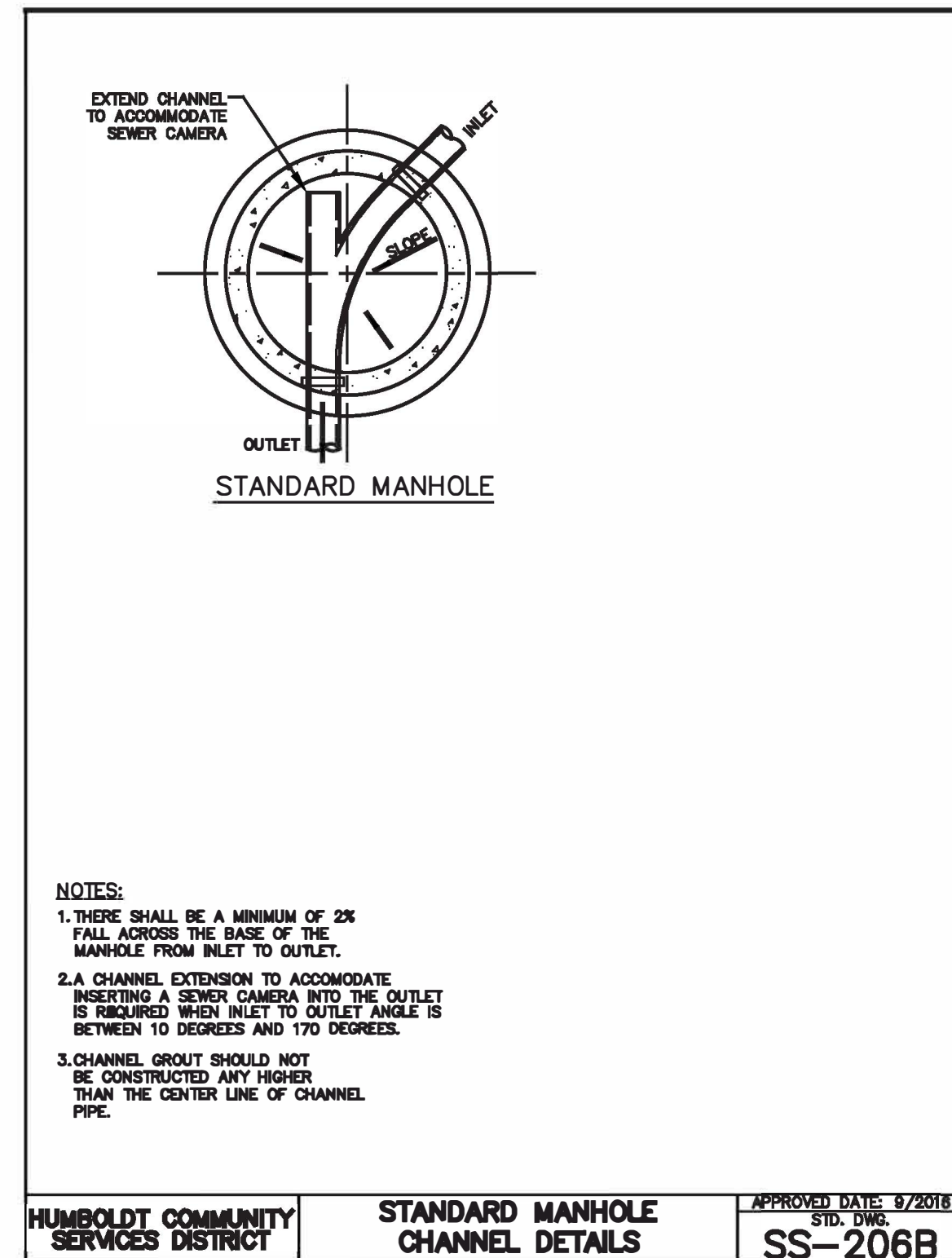
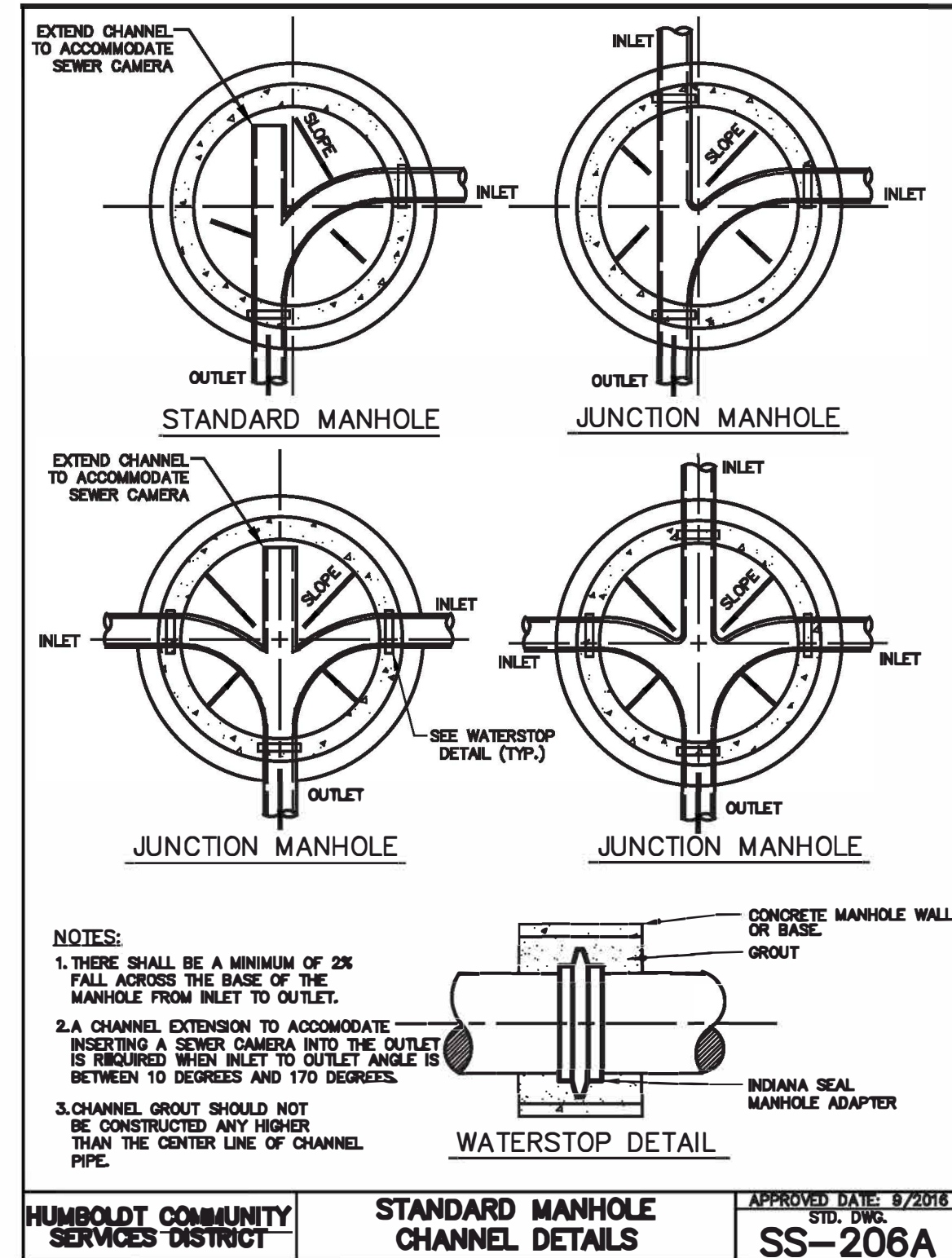
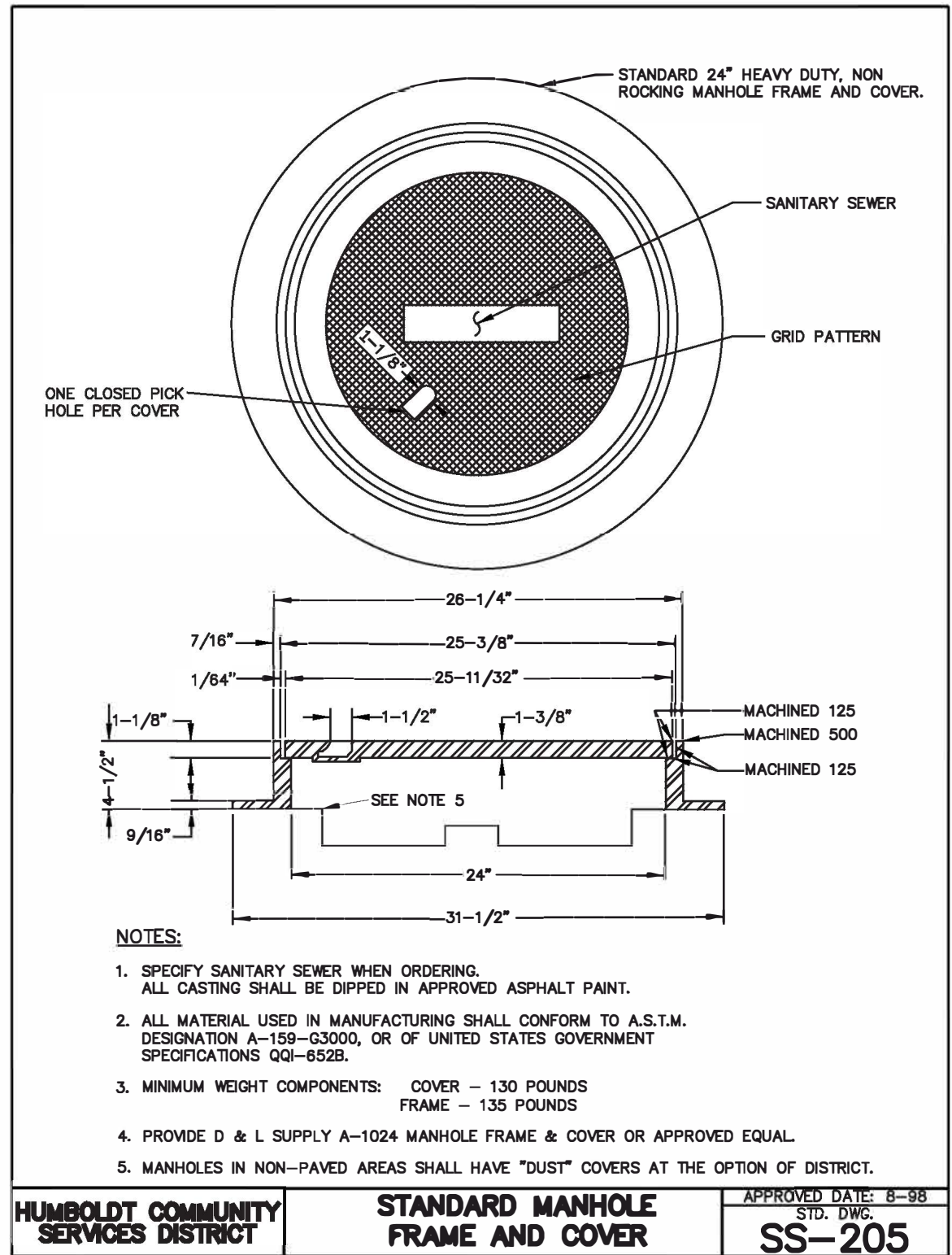
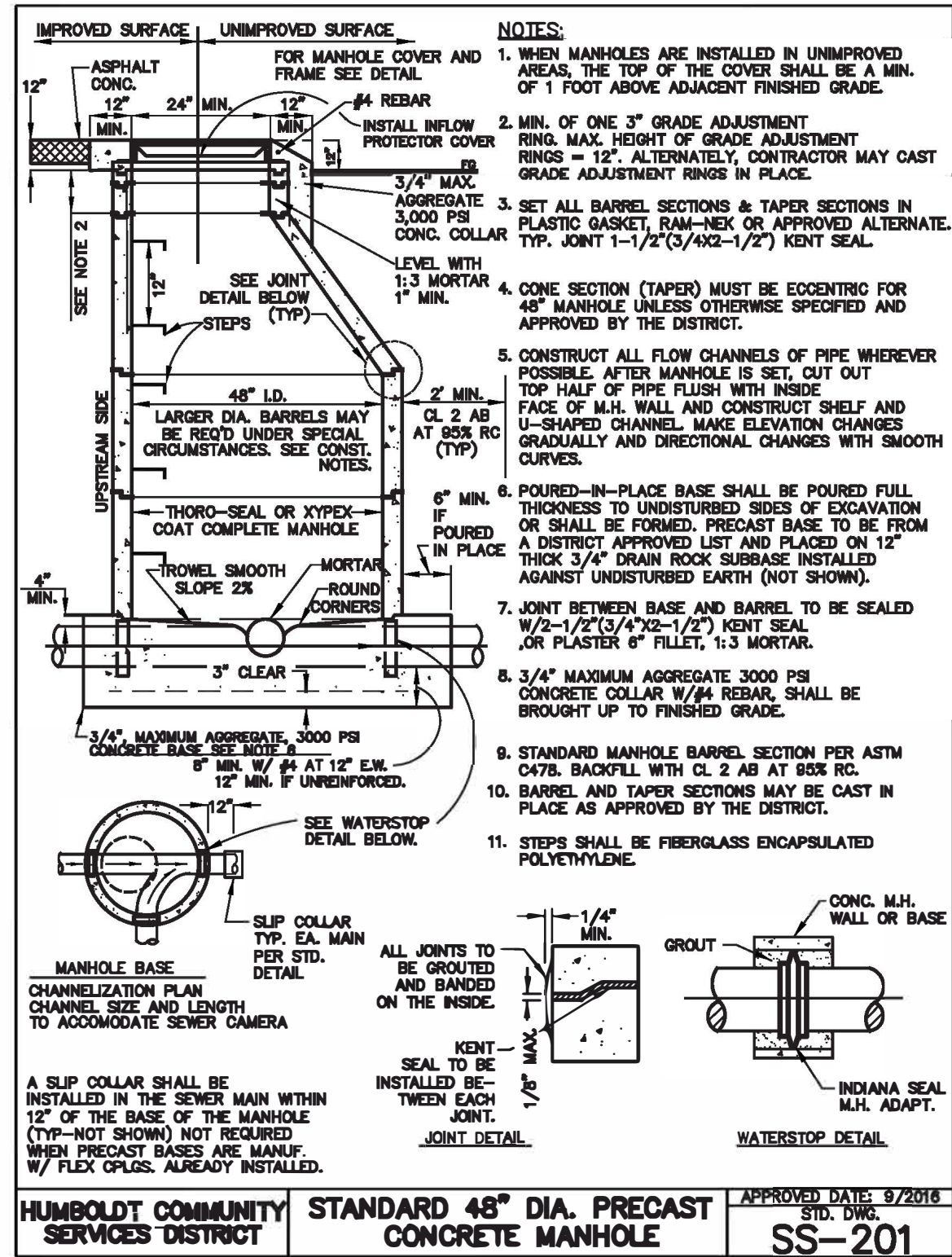

PART	INPUT	OUTPUT	BRAND
A	6" PVC SS	6" VC SS	FERNCO
B	6" VC SS	4" PVC SS	FERNCO
C	6" PVC SS	6" PVC SS	FERNCO
D	4" PVC SS	4" AC SS	FERNCO

**COUPLINGS**

**HUMBOLDT COMMUNITY SERVICES DISTRICT** | **COUPLINGS** | **DETAIL 1**

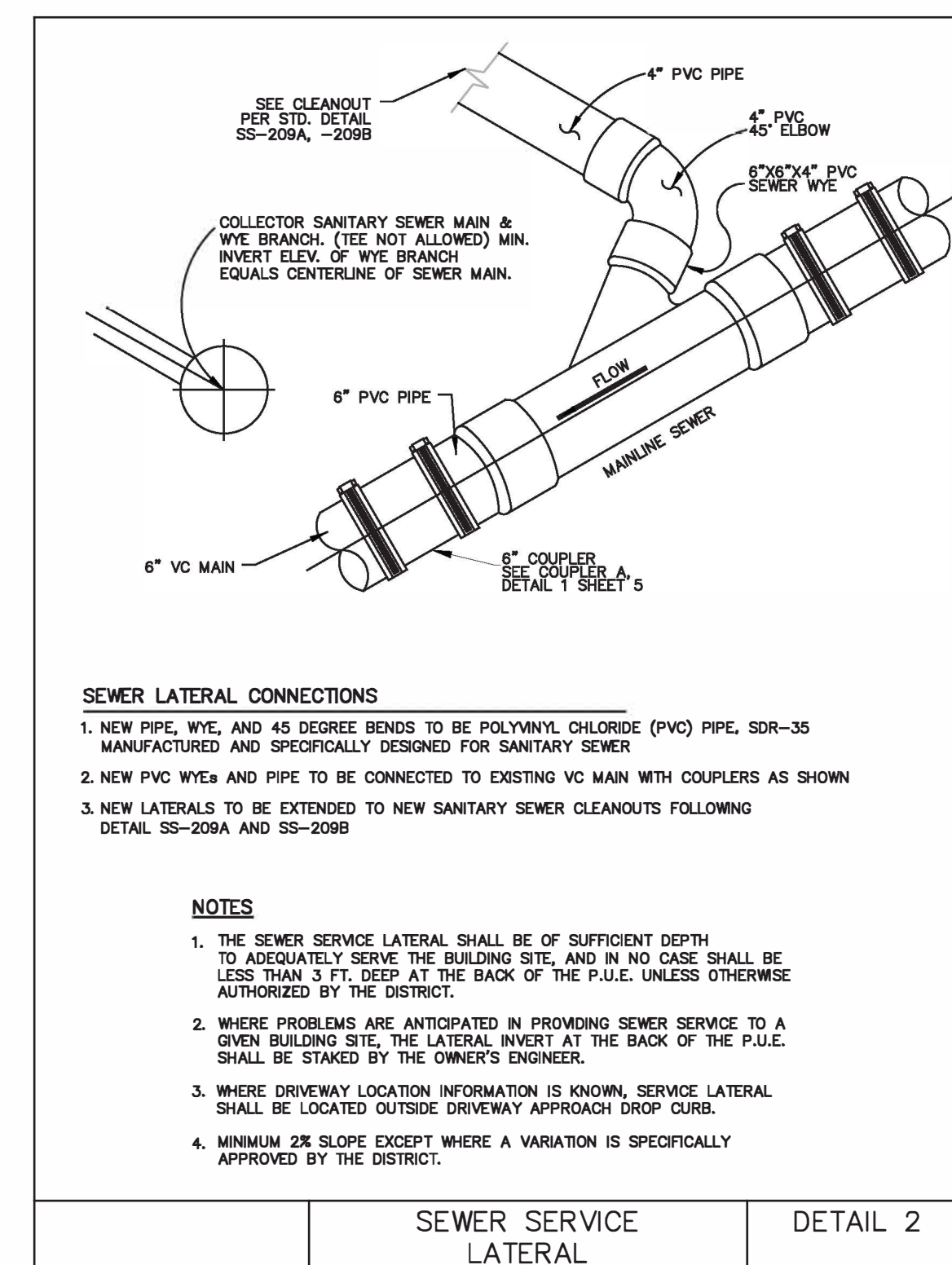
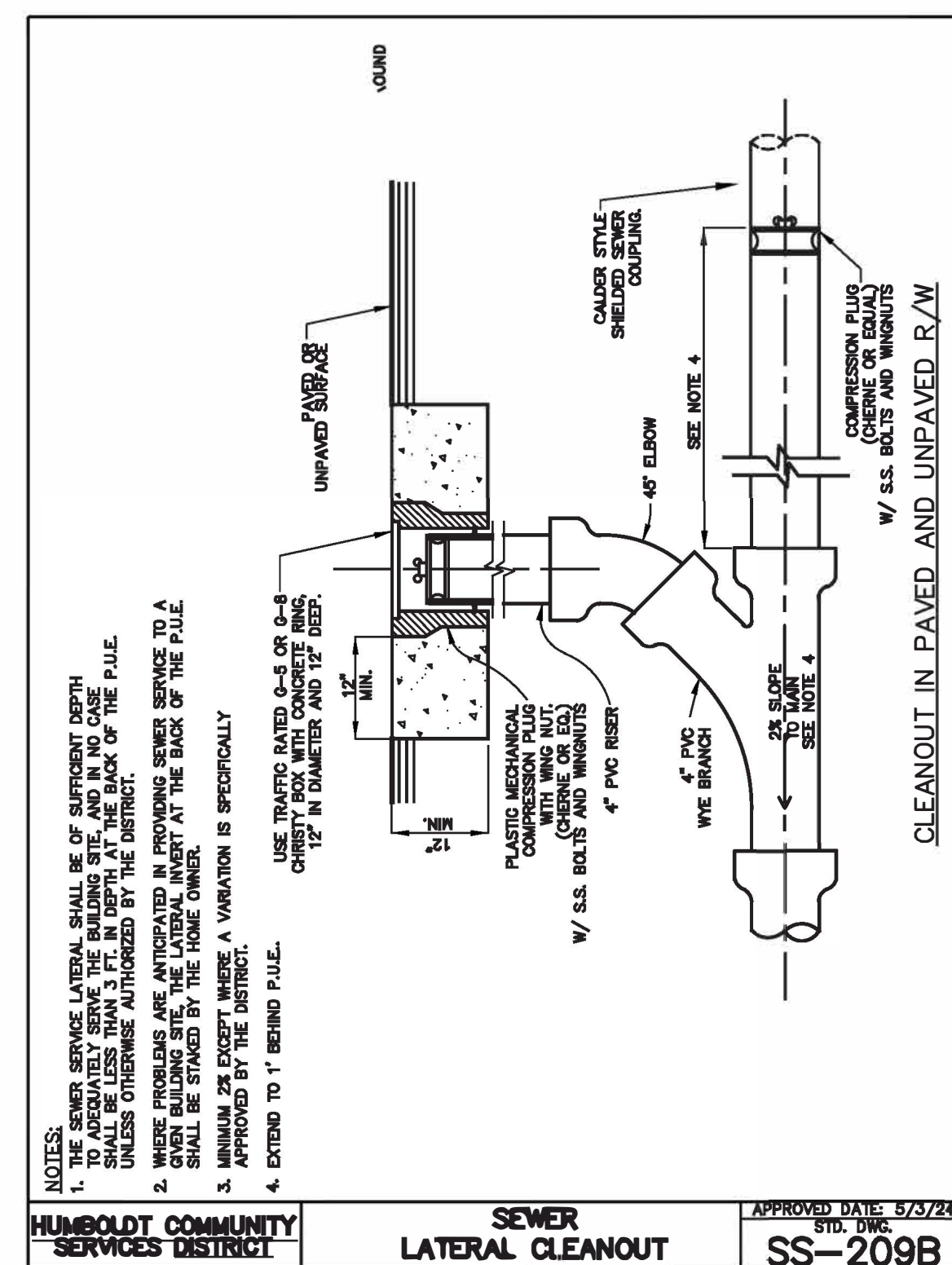
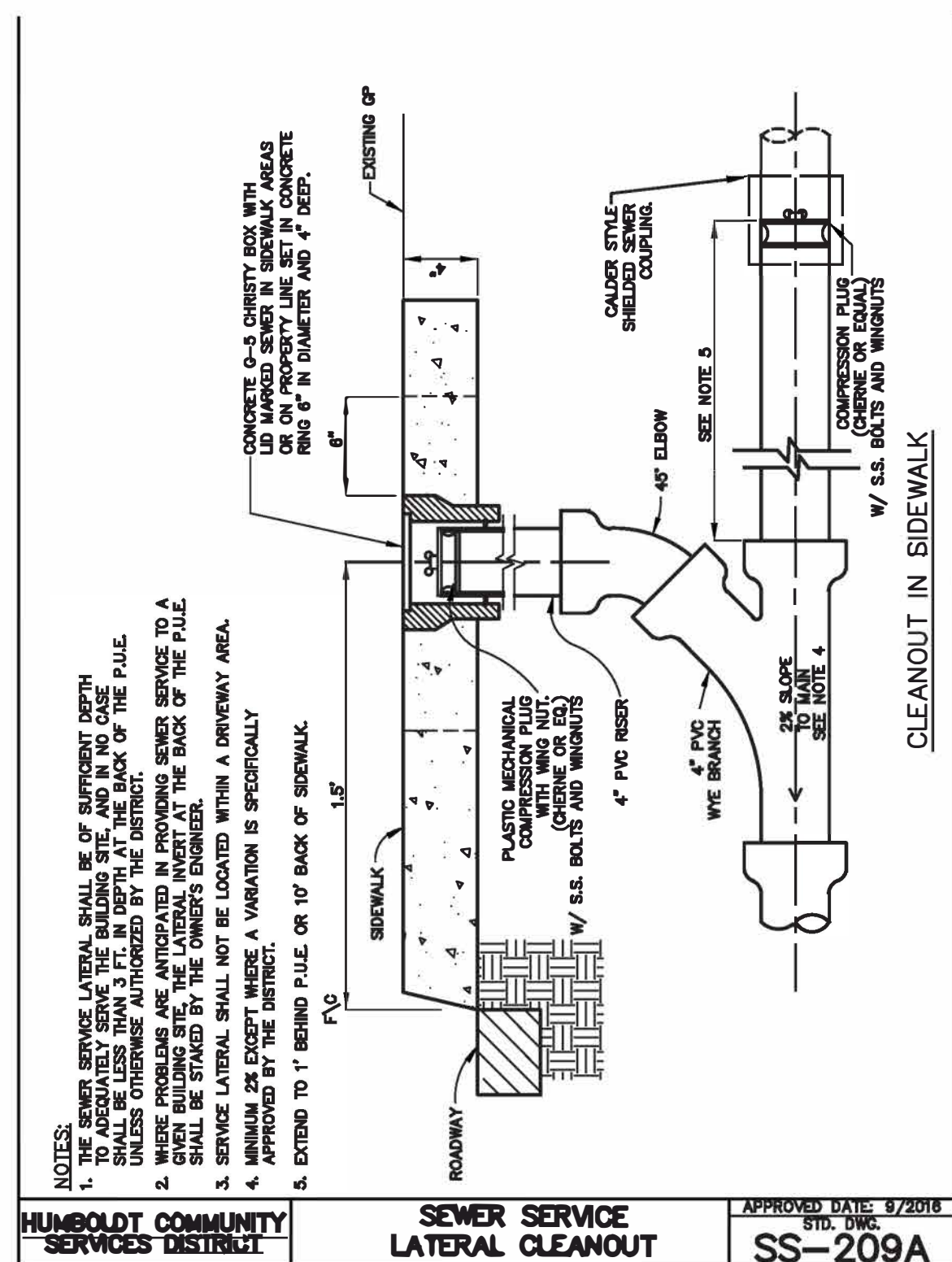

REVISIONS	BY
△ PLN_CHK 8-22-24	ALW
△ BID_PCKG 1-31-25	FMT

**WHITCHURCH ENGINEERING, INC.**  
 610 8th Street Fortuna, California 95540  
 Phone (707) 444-1420  
 No. 73755  
 CIVIL  
 STATE OF CALIFORNIA  
 2/4/2025

**DOCTOR'S OFFICE LANE SEWER REHAB DESIGN**  
 PROJECT ADDRESS: DR. OFFICE LN.  
 (2800-2820 HARRIS ST), EUREKA, CA 95503  
 APN: 017-015-023  
**STANDARD DETAILS**  
 For: HUMBOLDT COMMUNITY SERVICES DISTRICT, G.M. TERRENCE WILLIAMS

Date	JUL 17, 24'
Scale	AS NOTED
Design	ALW
Drawn	ALW
Job	HCD 2302.2
Sheet	5

THESE PLANS ARE ORIGINALLY PRINTED ON 22"x34" PAPER.

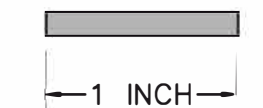

This drawing or drawing set shall not be used for construction unless a jurisdictional stamp (County, City, State, Federal) has been issued on the drawing, stating "FOR PERMIT" or similar verbiage, a wet signed professional engineer's stamp, and permit documents have been issued for the project.

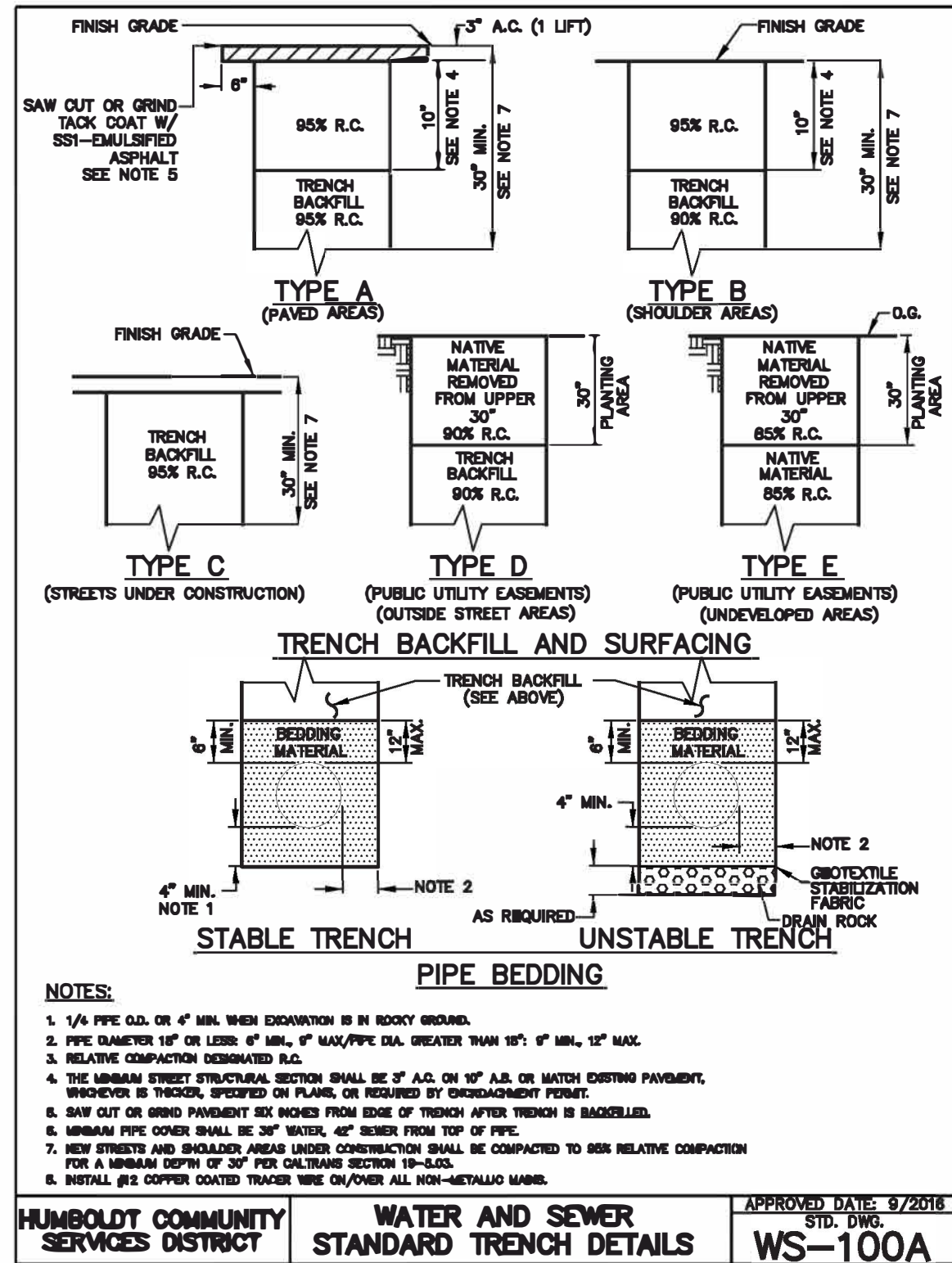

HUMBOLDT COMMUNITY SERVICES DISTRICT	WATER AND SEWER STANDARD TRENCH DETAILS	APPROVED DATE: 9/2016 STD. DWG. WS-100A
--------------------------------------	---	---

- I. MATERIAL SPECIFICATIONS:**
- BEDDING MATERIAL:**
    - PEA GRAVEL - CONFORMING TO CALTRANS SECTION 68-2.02F, PERMEABLE MATERIAL, CLASS 1, TYPE B.
    - CL 2 AB - CONFORMING TO CALTRANS SECTION 29-1.02, CLASS 2 AGGREGATE BASE, 3/4" MAXIMUM.
    - PERMEABLE - CONFORMING TO CALTRANS SECTION 68-2.02F, CLASS 2 PERMEABLE MATERIAL.
  - AGGREGATE BASE:**
    - CL 2 AB - CONFORMING TO CALTRANS SECTION 29-1.02, CLASS 2 AGGREGATE BASE, 3/4" MAXIMUM.
  - DRAIN ROCK:**
    - NO. 3 ROCK - SHALL BE A WASHED ROCK OF THE NOMINAL SIZE DESIGNATED AS 1" TO 2".
  - GABION ROCK:**
    - GABION ROCK - SHALL BE A WASHED OR NON-WASHED ROCK OF THE NOMINAL SIZE DESIGNATED AS 4" TO 12".
  - NATIVE MATERIAL:**
    - NATIVE MATERIAL - NATIVE MATERIAL USED AS BACKFILL SHALL BE FREE OF ORGANIC MATTER, REFUSE OR OTHER UNSATISFACTORY MATERIALS, STONES, OR LUMPS GREATER THAN OR EXCEEDING 3" IN GREATEST DIMENSION.
  - SHALE MATERIAL:**
    - SHALE MATERIAL - SHALE MATERIAL SHALL MEET THE QUALITY REQUIREMENTS FOR CL 2 AB AND CONTAIN ENOUGH FINE MATERIALS TO BE ABLE TO BE COMPACTED TO 95% RC IN A TIGHT SUSTAINABLE MATRIX.
- II. COMPACTION REQUIREMENTS:**
- BEDDING MATERIAL:**
    - PEA GRAVEL SHALL EITHER BE HAND TAMPED UNDER AND AT THE SIDES OF THE PIPES IN LIFTS NOT GREATER THAN 4" OR SHAPED AND COMPACTED PRIOR TO PIPE INSTALLATION.
    - CL 2 AB SHALL MEET THE ABOVE REQUIREMENTS AND SHALL ADDITIONALLY BE COMPACTED UNDER THE PIPE TO 90% RC AND UP TO THE SPRING LINE OF THE PIPE TO 90% RC IN TWO SEPARATE LIFTS RESULTING IN A FIRM UNYIELDING BEDDED TRENCH. JETTING SHALL NOT BE ALLOWED.
  - AGGREGATE BASE:**
    - AGGREGATE BASE SHALL BE COMPACTED WITH MECHANICAL HAND OPERATED, OR EQUIPMENT MOUNTED OR TOWED METHODS TO ACHIEVE THE REQUIRED COMPACTION. IN ANY EVENT, COMPACTION METHODS SHALL NOT DAMAGE THE PIPE, EXCEED THE LOADING CAPACITY OF THE PIPE, OR RESULT IN A CHANGE TO THE DESIGN PIPE SLOPE REQUIRED OR DEFLECTION UNITS. JETTING SHALL NOT BE ALLOWED.
  - DRAIN ROCK:**
    - DRAIN ROCK SHALL BE CONSOLIDATED WITH A SURFACE VIBRATOR.
  - SHALE MATERIAL:**
    - SHALE SHALL MEET THE COMPACTION REQUIREMENTS FOR CL 2 AB.
  - NATIVE MATERIAL:**
    - NATIVE MATERIAL COMPACTED TO 90% RC SHALL MEET THE COMPACTION REQUIREMENTS OF CL 2 AB. NATIVE MATERIAL COMPACTED TO LESS THAN 90% RC MAY BE COMPACTED BY WHEEL ROLLING.

HUMBOLDT COMMUNITY SERVICES DISTRICT	WATER AND SEWER STANDARD TRENCH DETAIL NOTES	APPROVED DATE: 9/2016 STD. DWG. WS-100B
--------------------------------------	--	---

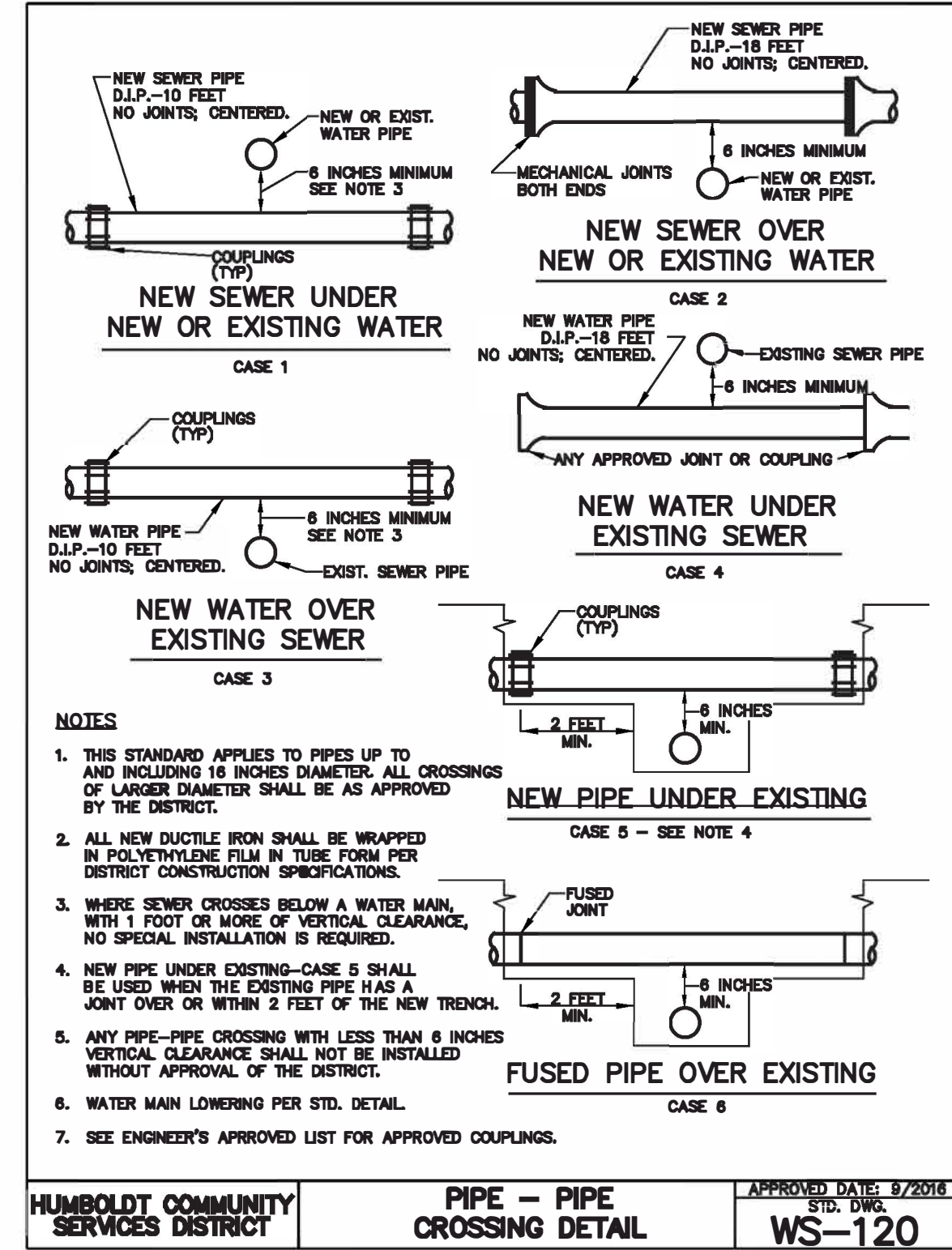

HUMBOLDT COMMUNITY SERVICES DISTRICT	PIPE - PIPE CROSSING DETAIL	APPROVED DATE: 9/2016 STD. DWG. WS-120
--------------------------------------	-----------------------------	--

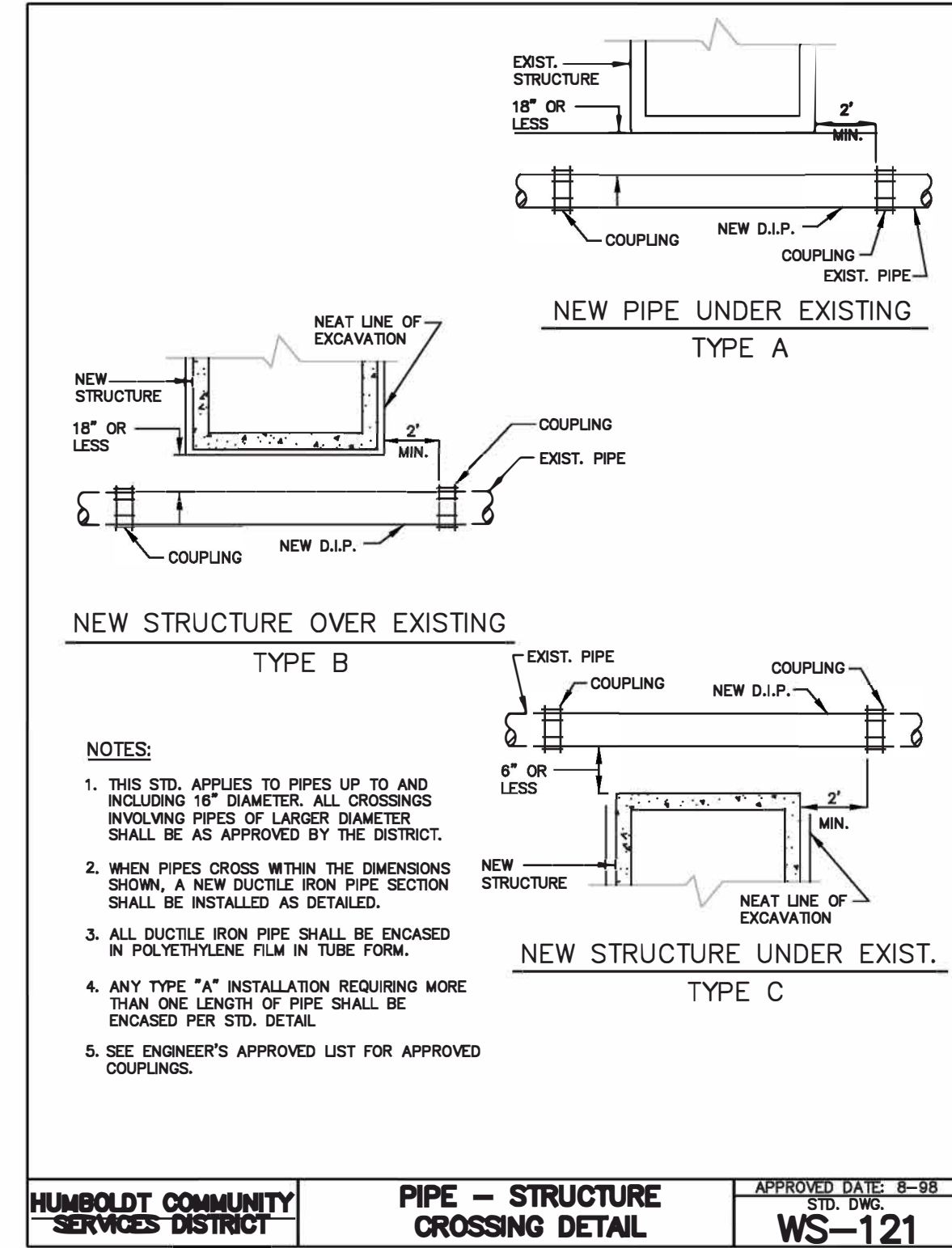

HUMBOLDT COMMUNITY SERVICES DISTRICT	PIPE - STRUCTURE CROSSING DETAIL	APPROVED DATE: 8-98 STD. DWG. WS-121
--------------------------------------	----------------------------------	--

THESE PLANS ARE ORIGINALLY PRINTED ON 22"x34" PAPER.

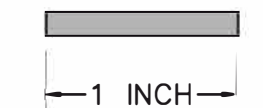

REVISIONS	BY
△ PLN CHK 8-22-24	ALW
△ BID PKG 1-31-25	FMT



**WHITCHURCH ENGINEERING, INC.**  
 610 8th Street Fortuna, California 95540  
 Phone (707) 444-1420

**DOCTOR'S OFFICE LANE SEWER REHAB DESIGN**  
 PROJECT ADDRESS: DR. OFFICE LN.  
 (2800-2820 HARRIS ST), EUREKA, CA 95503  
 APN: 017-015-023

**STANDARD DETAILS**  
 For: HUMBOLDT COMMUNITY SERVICES DISTRICT, G.M. TERRENCE WILLIAMS

Date	JUL 17, 24'
Scale	AS NOTED
Design	ALW
Drawn	ALW
Job	HCD 2302.2
Sheet	6

This drawing or drawing set shall not be used for construction unless a jurisdictional stamp (County, City, State, Federal) has been issued on the drawing, stating "FOR PERMIT" or similar verbiage, a wet signed professional engineer's stamp, and permit documents have been issued for the project.